

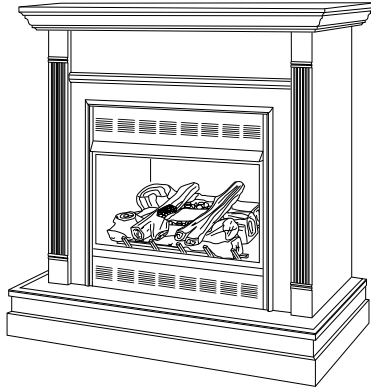
# DESA™

HEATING PRODUCTS

## UNVENTED (VENT-FREE) GAS FIREPLACE OWNER'S OPERATION AND INSTALLATION MANUAL



Patent Pending



We recommend that our products be installed and serviced by professionals who are certified in the U.S. by NFI (National Fireplace Institute).

[www.nfpcertified.org](http://www.nfpcertified.org)

Shown with optional cabinet mantel and hearth base accessories.

### LMFP33NR(A) AND LMFP33PR(A) REMOTE CONTROL GAS FIREPLACE SYSTEMS

**WARNING:** If the information in this manual is not followed exactly, a fire or explosion may result causing property damage, personal injury or loss of life.

- Do not store or use gasoline or other flammable vapors and liquids in the vicinity of this or any other appliance.
- **WHAT TO DO IF YOU SMELL GAS**
  - Do not try to light any appliance.
  - Do not touch any electrical switch; do not use any phone in your building.
  - Immediately call your gas supplier from a neighbor's phone. Follow the gas supplier's instructions.
  - If you cannot reach your gas supplier, call the fire department.
- Installation and service must be performed by a qualified installer, service agency or the gas supplier.

**INSTALLER:** Leave this manual with the appliance.  
**CONSUMER:** Retain this manual for future reference.

---

## CONTENTS

Safety Information .....	2	Troubleshooting .....	25
Product identification .....	4	Specifications .....	29
Local Codes .....	5	Wiring Diagram .....	29
Unpacking .....	5	Technical Service .....	29
Product Features .....	5	Service Hints .....	29
Air for Combustion and Ventilation .....	5	Replacement Parts .....	29
Installation .....	8	Illustrated Parts Breakdown and Parts List .....	30
Operating Heater .....	20	Accessories .....	34
Inspecting Burners .....	23	Warranty Information .....	Back Cover
Cleaning and Maintenance .....	24		

## SAFETY INFORMATION

**WARNING:** Improper installation, adjustment, alteration, service or maintenance can cause injury or property damage. Refer to this manual for correct installation and operational procedures. For assistance or additional information consult a qualified installer, service agency or the gas supplier.

This appliance may be installed in an aftermarket,\* permanently located, manufactured (mobile) home, where not prohibited by local codes.

This appliance is only for use with the type of gas indicated on the rating plate. This appliance is not convertible for use with other gases.

\* **Aftermarket:** Completion of sale, not for purpose of resale, from the manufacturer

**WARNING:** This is an unvented gas-fired heater. It uses air (oxygen) from the room in which it is installed. Provisions for adequate combustion and ventilation air must be provided. Refer to *Air for Combustion and Ventilation* section on page 5 of this manual.

**State of Massachusetts:** The installation must be made by a licensed plumber or gas fitter in the Commonwealth of Massachusetts.

Sellers of unvented propane or natural gas-fired supplemental room heaters shall provide to each purchaser a copy of 527 CMR 30 upon sale of the unit.

Vent-free gas products are prohibited for bedroom and bathroom installation in the Commonwealth of Massachusetts.

## SAFETY INFORMATION

*Continued*

**⚠ WARNING:** This product contains and/or generates chemicals known to the State of California to cause cancer or birth defects or other reproductive harm.

**IMPORTANT:** Read this owner's manual carefully and completely before trying to assemble, operate or service this heater. Improper use of this heater can cause serious injury or death from burns, fire, explosion, electrical shock and carbon monoxide poisoning.

**⚠ DANGER:** Carbon monoxide poisoning may lead to death!

**Carbon Monoxide Poisoning:** Early signs of carbon monoxide poisoning resemble the flu, with headaches, dizziness or nausea. If you have these signs, the heater may not be working properly. **Get fresh air at once!** Have heater serviced. Some people are more affected by carbon monoxide than others. These include pregnant women, people with heart or lung disease or anemia, those under the influence of alcohol and those at high altitudes.

**Natural and Propane/LP Gas:** Natural and propane/LP gases are odorless. An odor-making agent is added to the gas. The odor helps you detect a gas leak. However, the odor added to the gas can fade. Gas may be present even though no odor exists. Make certain you read and understand all warnings. Keep this manual for reference. It is your guide to safe and proper operation of this heater.

**⚠ WARNING:** Any change to this heater or its controls can be dangerous.

**⚠ WARNING:** Do not allow fans to blow directly into the fireplace. Avoid any drafts that alter burner flame patterns. Ceiling fans can create drafts that alter burner flame patterns. Altered burner patterns can cause sooting.

**⚠ WARNING:** Do not use a blower insert, heat exchanger insert or other accessory not approved for use with this heater.

Due to high temperatures, the appliance should be located out of traffic and away from furniture and draperies.

Do not place clothing or other flammable material on or near the appliance. Never place any objects on the heater.

Fireplace and screen become very hot when running fireplace. Keep children and adults away from hot surfaces to avoid burns or clothing ignition. Fireplace will remain hot for a time after shutdown. Allow surfaces to cool before touching.

Carefully supervise young children when they are in the room with fireplace. When using the optional hand-held remote accessory, keep selector switch in the OFF position to prevent children from turning on burners with remote.

You must operate this fireplace with the fireplace screen and hood in place. Make sure fireplace screen and hood are in place before running heater.

Keep the appliance area clear and free from combustible materials, gasoline and other flammable vapors and liquids.

## SAFETY INFORMATION

### Continued

1. This appliance is only for use with the type of gas indicated on the rating plate. This appliance is not convertible for use with other gases.
2. Do not place propane/LP supply tank(s) inside any structure. Locate propane/LP supply tank(s) outdoors (propane/LP units only).
3. If you smell gas
  - shut off gas supply
  - do not try to light any appliance
  - do not touch any electrical switch; do not use any phone in your building
  - immediately call your gas supplier from a neighbor's phone. Follow the gas supplier's instructions
  - if you cannot reach your gas supplier, call the fire department
4. This fireplace shall not be installed in a bedroom or bathroom.
5. Do not use this fireplace as a wood-burning fireplace. Use only the logs provided with the fireplace.
6. Do not add extra logs or ornaments such as pine cones, vermiculite or rock wool. Using these added items can cause sooting. Do not add lava rock around base. Rock and debris could fall into the control area of fireplace.
7. To prevent the creation of soot, follow the instructions in *Cleaning and Maintenance*, page 24.
8. Before using furniture polish, wax, carpet cleaner or similar products, turn heater off. If heated, the vapors from these products may create a white powder residue within burner box or on adjacent walls or furniture.
9. This fireplace needs fresh air ventilation to run properly. This fireplace has an Oxygen Depletion Sensing (ODS) safety shutoff system. The ODS shuts down the fireplace if enough fresh air is not available. See *Air for Combustion and Ventilation*, page 5. If fireplace keeps shutting off, see *Troubleshooting*, page 25.
10. Do not run fireplace
  - where flammable liquids or vapors are used or stored
  - under dusty conditions
11. Do not use this fireplace to cook food or burn paper or other objects.
12. Do not use fireplace if any part has been exposed to or under water. Immediately call a qualified service technician to inspect the fireplace and to replace any part of the control system and any gas control which has been under water.
13. Do not operate fireplace if any log is broken. Do not operate fireplace if a log is chipped (dime-sized or larger).
14. Turn fireplace off and let cool before servicing. Only a qualified service person should service and repair fireplace.
15. Operating fireplace above elevations of 4,500 feet could cause pilot outage.
16. To prevent performance problems in propane/LP units, do not use propane/LP fuel tanks of less than 100 lbs. capacity (propane/LP units only).
17. Provide adequate clearances around air openings.

## PRODUCT IDENTIFICATION

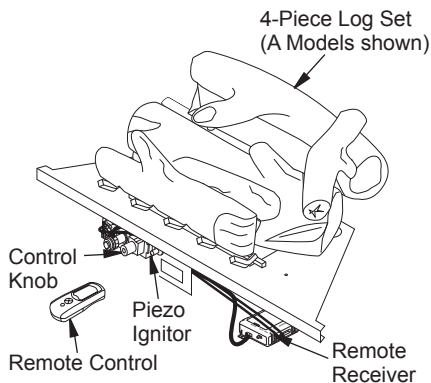


Figure 1 - Log Base Assembly

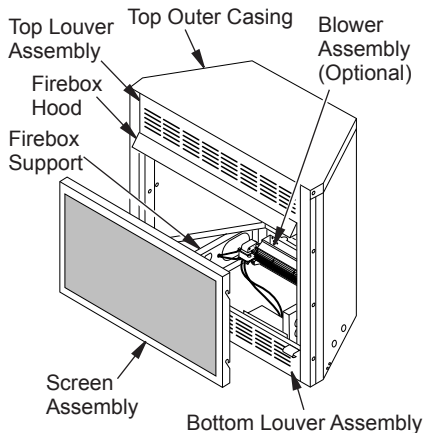


Figure 2 - Fireplace (LMFP33PR Shown)

## LOCAL CODES

Install and use fireplace with care. Follow all local codes. In the absence of local codes, use the latest edition of *The National Fuel Gas Code ANSI Z223.1/NFPA 54\**.

\*Available from:

American National Standards Institute, Inc.  
1430 Broadway  
New York, NY 10018

National Fire Protection Association, Inc.  
Batterymarch Park  
Quincy, MA 02269

*Note:* Where listed vented decorative logs are required, thermostat operation is not permitted.

## UNPACKING

**⚠ CAUTION: Do not remove the data plates attached to the heater base assembly. The data plates contain important warranty and safety information.**

1. With utility knife, cut the carton all the way around above the staples on the bottom tray. Lift the carton off the heater. Remove packing. *Note:* The hood is located in the packing on the right hand side of the heater front. Lift the heater off the bottom tray.
2. Locate two screws above top corners of the fireplace screen. Remove and discard these screws. Lift fireplace screen up and pull out to remove.
3. Remove protective packaging applied to logs, log base assembly and fireplace.
4. Remove fireplace hood from carton insert.
5. Check all items for any shipping damage. If damaged, promptly inform dealer where you bought fireplace.

## PRODUCT FEATURES

### OPERATION

This vent-free fireplace is clean burning. It requires no outside venting. There is no heat loss out a vent or up a chimney. Heat is generated by both realistic flames. When used without the blower, the fireplace requires no electricity making it ideal for emergency backup heat. This heater is designed for vent-free operation. It has been tested and approved to ANSI Z21.11.2 standard for unvented heaters. State and local codes in some areas prohibit the use of vent-free heaters.

## SAFETY DEVICE

This fireplace has a pilot with an Oxygen Depletion Sensing (ODS) safety shutoff system. The ODS/pilot is a required feature for vent-free room heaters. The ODS/pilot system shuts off the fireplace if there is not enough fresh air.

## PIEZO IGNITION SYSTEM

This fireplace has a piezo ignitor. This system requires no matches, batteries or other sources to light fireplace.

## OPTIONAL BLOWER ASSEMBLY (GA3750 SERIES & GA3650TB SERIES)

This fireplace accepts an optional blower assembly (not included). The GA3650TB Series blower operates thermostatically and features a variable speed control. The GA3750 Series blower operates manually and also features a variable speed control. The blower circulates heated air from the fireplace into the room. See *Accessories*, page 34.

## AIR FOR COMBUSTION AND VENTILATION

**⚠ WARNING: This heater shall not be installed in a confined space or unusually tight construction unless provisions are provided for adequate combustion and ventilation air. Read the following instructions to insure proper fresh air for this and other fuel-burning appliances in your home.**

Today's homes are built more energy efficient than ever. New materials, increased insulation and new construction methods help reduce heat loss in homes. Home owners weather strip and caulk around windows and doors to keep the cold air out and the warm air in. During heating months, home owners want their homes as airtight as possible.

While it is good to make your home energy efficient, your home needs to breathe. Fresh air must enter your home. All fuel-burning appliances need fresh air for proper combustion and ventilation.

Exhaust fans, fireplaces, clothes dryers and fuel burning appliances draw air from the house to operate. You must provide adequate fresh air for these appliances. This will insure proper venting of vented fuel-burning appliances.

# AIR FOR COMBUSTION AND VENTILATION

*Continued*

## PROVIDING ADEQUATE VENTILATION

The following are excerpts from *National Fuel Gas Code, ANSI Z223.1/NFPA 54, Section 5.3, Air for Combustion and Ventilation*.

All spaces in homes fall into one of the three following ventilation classifications:

1. Unusually Tight Construction
2. Unconfined Space
3. Confined Space

The information on pages 5 through 7 will help you classify your space and provide adequate ventilation.

### Unusually Tight Construction

The air that leaks around doors and windows may provide enough fresh air for combustion and ventilation. However, in buildings of unusually tight construction, you must provide additional fresh air.

**Unusually tight construction is defined as construction where:**

- a. walls and ceilings exposed to the outside atmosphere have a continuous water vapor retarder with a rating of one perm ( $6 \times 10^{-11}$  kg per pa-sec- $m^2$ ) or less with openings gasketed or sealed and
- b. weather stripping has been added on openable windows and doors and
- c. caulking or sealants are applied to areas such as joints around window and door frames, between sole plates and floors, between wall-ceiling joints, between wall panels, at penetrations for plumbing, electrical and gas lines and at other openings.

**If your home meets all of the three criteria above, you must provide additional fresh air. See *Ventilation Air From Outdoors*, page 7.**

**If your home does not meet all of the three criteria above, proceed to *Determining Fresh-Air Flow For Heater Location*.**

## Confined and Unconfined Space

*The National Fuel Gas Code, ANSI Z223.1/NFPA 54* defines a confined space as a space whose volume is less than 50 cubic feet per 1,000 Btu per hour ( $4.8 \text{ m}^3$  per kw) of the aggregate input rating of all appliances installed in that space and an unconfined space as a space whose volume is not less than 50 cubic feet per 1,000 Btu per hour ( $4.8 \text{ m}^3$  per kw) of the aggregate input rating of all appliances installed in that space. Rooms communicating directly with the space in which the appliances are installed\*, through openings not furnished with doors, are considered a part of the unconfined space.

\* Adjoining rooms are communicating only if there are doorless passageways or ventilation grills between them.

## DETERMINING FRESH-AIR FLOW FOR FIREPLACE LOCATION

### Determining if You Have a Confined or Unconfined Space

Use this work sheet to determine if you have a confined or unconfined space.

**Space:** Includes the room in which you will install fireplace plus any adjoining rooms with doorless passageways or ventilation grills between the rooms.

1. Determine the volume of the space (length x width x height).

Length x Width x Height = \_\_\_\_\_ cu. ft.  
(volume of space)

*Example:* Space size 20 ft. (length) x 16 ft. (width) x 8 ft. (ceiling height) = 2,560 cu. ft. (volume of space)

If additional ventilation to adjoining room is supplied with grills or openings, add the volume of these rooms to the total volume of the space.

2. Multiply the space volume by 20 to determine the maximum Btu/Hr the space can support.

\_\_\_\_\_ (volume of space) x 20 = (Maximum Btu/Hr the space can support)

*Example:* 2,560 cu. ft. (volume of space) x 20 = 51,200 (maximum Btu/Hr the space can support)

3. Add the Btu/Hr of all fuel burning appliances in the space.

Vent-free fireplace	_____ Btu/Hr
Gas water heater*	_____ Btu/Hr
Gas furnace	_____ Btu/Hr
Vented gas heater	_____ Btu/Hr
Gas fireplace logs	_____ Btu/Hr
Other gas appliances*	+ _____ Btu/Hr
Total	= _____ Btu/Hr

\* Do not include direct-vent gas appliances. Direct-vent draws combustion air from the outdoors and vents to the outdoors.

# AIR FOR COMBUSTION AND VENTILATION

*Continued*

*Example:*

Gas water heater	$\frac{40,000}{\quad}$	Btu/Hr
Vent-free fireplace	$+ \frac{33,000}{\quad}$	Btu/Hr
Total	$= \frac{73,000}{\quad}$	Btu/Hr

4. Compare the maximum Btu/Hr the space can support with the actual amount of Btu/Hr used.

\_\_\_\_\_ Btu/Hr (maximum the space can support)

\_\_\_\_\_ Btu/Hr (actual amount of Btu/Hr used)

*Example:* 51,200 Btu/Hr (maximum the space can support)

73,000 Btu/Hr (actual amount of Btu/Hr used)

The space in the example is a confined space because the actual Btu/Hr used is more than the maximum Btu/Hr the space can support. You must provide additional fresh air. Your options are as follows:

- A. Rework worksheet, adding the space of an adjoining room. If the extra space provides an unconfined space, remove door to adjoining room or add ventilation grills between rooms. See *Ventilation Air From Inside Building*.
- B. Vent room directly to the outdoors. See *Ventilation Air From Outdoors*.
- C. Install a lower Btu/Hr fireplace, if lower Btu/Hr size makes room unconfined.

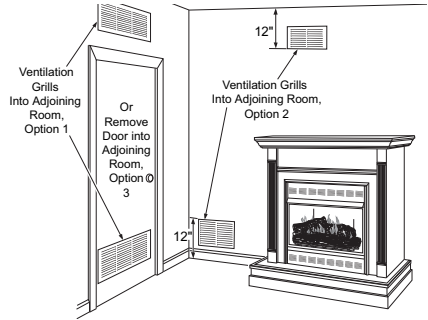
If the actual Btu/Hr used is less than the maximum Btu/Hr the space can support, the space is an unconfined space. You will need no additional fresh air ventilation.

**⚠ WARNING:** If the area in which the heater may be operated is smaller than that defined as an unconfined space or if the building is of unusually tight construction, provide adequate combustion and ventilation air by one of the methods described in the *National Fuel Gas Code, ANSI Z223.1/NFPA 54 Section 5.3* or applicable local codes.

## VENTILATION AIR

### Ventilation Air From Inside Building

This fresh air would come from an adjoining unconfined space. When ventilating to an adjoining unconfined space, you must provide two permanent openings: one within 12" of the ceiling and one within 12" of the floor on the wall connecting the two spaces (see options 1 and 2, Figure 3). You can also remove door into adjoining room (see option 3, Figure 3). Follow the *National Fuel Gas Code, ANSI Z223.1/NFPA 54, Section 5.3, Air for Combustion and Ventilation* for required size of ventilation grills or ducts.

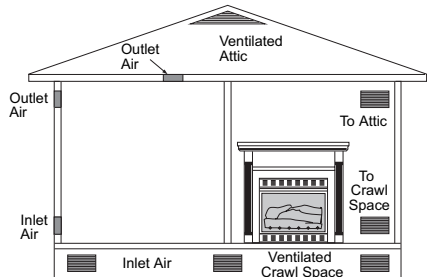


**Figure 3 - Ventilation Air from Inside Building**

### Ventilation Air From Outdoors

Provide extra fresh air by using ventilation grills or ducts. You must provide two permanent openings: one within 12" of the ceiling and one within 12" of the floor. Connect these items directly to the outdoors or spaces open to the outdoors. These spaces include attics and crawl spaces. Follow the *National Fuel Gas Code, ANSI Z223.1/NFPA 54, Section 5.3, Air for Combustion and Ventilation* for required size of ventilation grills or ducts.


**IMPORTANT:** Do not provide openings for inlet or outlet air into attic if attic has a thermostat-controlled power vent. Heated air entering the attic will activate the power vent.



**Figure 4 - Ventilation Air from Outdoors**


## INSTALLATION

**NOTICE:** This heater is intended for use as supplemental heat. Use this heater along with your primary heating system. Do not install this heater as your primary heat source. If you have a central heating system, you may run system's circulating blower while using heater. This will help circulate the heat throughout the house. In the event of a power outage, you can use this heater as your primary heat source.

 **WARNING:** A qualified service person must install fireplace. Follow all local codes.

 **WARNING:** Never install the fireplace

- in a bedroom or bathroom
- in a recreational vehicle
- where curtains, furniture, clothing or other flammable objects are less than 42 inches from the front, top or sides of the heater
- in high traffic areas
- in windy or drafty areas

 **CAUTION:** This fireplace creates warm air currents. These currents move heat to wall surfaces next to fireplace. Installing fireplace next to vinyl or cloth wall coverings or operating heater where impurities (such as, but not limited to, tobacco smoke, aromatic candles, cleaning fluids, oil or kerosene lamps, etc.) in the air exist, may discolor walls or cause odors.


*Note:* Your fireplace is designed to be used in zero clearance installations. Wall or framing material can be placed directly against any exterior surface on the rear, sides or top of your fireplace, except where standoff spacers are integrally attached. If standoff spacers are attached to your fireplace, these spacers can be placed directly against wall or framing materials.

Use the dimensions shown for rough openings to create the easiest installation. See *Built-In Fireplace Installation*, page 11.

**IMPORTANT:** Vent-free heaters add moisture to the air. Although this is beneficial, installing fireplace in rooms without enough ventilation air may cause mildew to form from too much moisture. See *Air for Combustion and Ventilation*, page 5. **IMPORTANT:** Make sure the fireplace is level. If fireplace is not level, log set will not work properly.

### CHECK GAS TYPE

Use the correct gas type (natural or propane/LP) for your fireplace. If your gas supply is not correct, do not install fireplace. Call dealer where you bought fireplace for proper type fireplace.

 **WARNING:** This appliance is equipped for (natural or propane/LP) gas. Field conversion is not permitted.

### ELECTRICAL HOOKUP

**(Models GA3750 Series and GA3650TB Series Blower Accessories and GA3555 Internal Duplex Kit)**

This fireplace accepts a blower assembly with an electrical cord. The electrical cord is five feet in length. You must locate fireplace within reach of a 120 volt grounded electrical outlet. If not, you must install an electrical outlet within reach of fireplace power cord. The GA3555 outlet accessory is used for built-in applications with blower accessory installed.

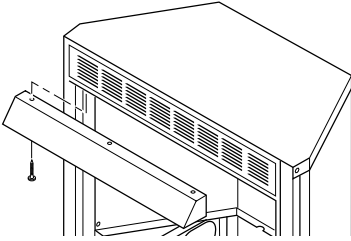


# INSTALLATION

*Continued*

## INSTALLING HOOD

Install hood to top of firebox as shown in Figure 5. Use 3 Phillips screws provided

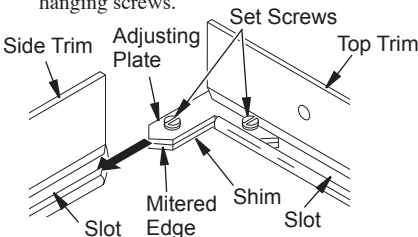


**Figure 5 - Installing Hood to Firebox**

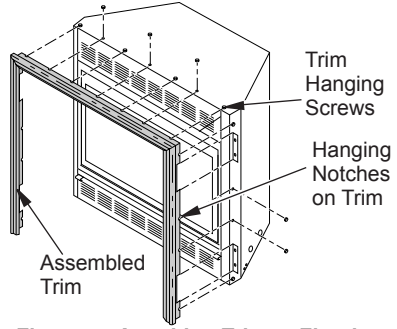
## ASSEMBLING AND ATTACHING OPTIONAL TRIM (Included with Mantel Accessory)

**IMPORTANT:** If you are recessing the firebox in a wall, do not attach trim at this time. See page 11.  
**Note:** The instructions below show assembling and attaching trim to fireplace.

1. Remove packaging from three pieces of trim.
2. Locate four brass screws, two adjusting plates with set screws and two shims in the hardware packet.
3. Align shim under adjusting plate as shown in Figure 6.
4. Slide one end of adjusting plate/shim in slot on mitered edge of top trim (see Figure 6).
5. Slide other end of adjusting plate/shim in slot on mitered edge of side trim (see Figure 6).
6. While firmly holding edges of trim together, tighten both set screws on the adjusting plate with slotted screwdriver.
7. Repeat steps 1 through 6 for other side.
8. Tighten trim hanging screws (#10 x 6.25 shoulder) into holes in cabinets. Place the assembled trim onto fireplace cabinet. Align hanging notches on trim with hanging screws on side of fireplace (see Figure 7). Push trim firmly into place, sliding hanging notches over hanging screws.



**Figure 6 - Assembling Trim**



**Figure 7 - Attaching Trim to Fireplace**

## INSTALLATION CLEARANCES

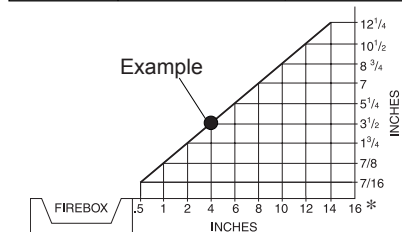
**⚠ WARNING:** Maintain the minimum clearances. If you can, provide greater clearances from floor, ceiling and adjoining wall.

Carefully follow the instructions below. This will ensure safe installation.

### Minimum Clearances For Side Combustible Material, Side Wall and Ceiling

- A. Clearances from the side of the fireplace cabinet to any combustible material and wall should follow diagram in Figure 8.
- Example:* The face of a mantel, bookshelf, etc. is made of combustible material and protrudes 3 1/2" from the wall. This combustible material must be 4" from the side of the fireplace opening (see Figure 8).
- B. Clearances from the top of the fireplace opening to the ceiling should not be less than 42 inches.

MINIMUM CLEARANCE TO COMBUSTIBLE MATERIALS		
Top	Left and Right Sides	Bottom and Rear
42"	16"	0"



\*Minimum 16 inches from Side Wall

**Figure 8 - Minimum Clearance for Combustible to Wall**

# INSTALLATION

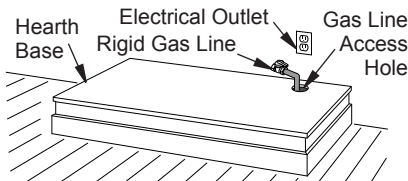
*Continued*

## CONVENTIONAL FIREPLACE INSTALLATION

Conventional installation of this fireplace involves installing fireplace along with the corner, face or cabinet mantel with hearth base accessories against a wall in your home. Follow the instructions below to install the fireplace in this manner.

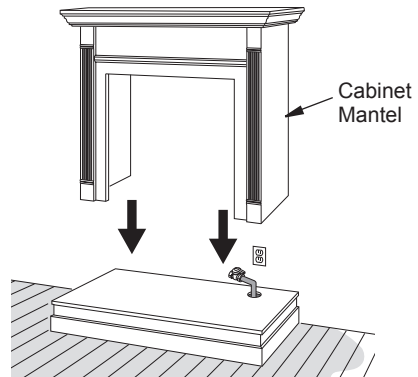
**Note:** The instructions in this section show installation using the cabinet mantel and hearth base accessories. The hearth base accessory shown is optional for this installation. You can install fireplace and cabinet mantel directly on the floor.

1. Assemble cabinet mantel, hearth base and trim accessories. Assembly instructions are included with each accessory.
2. When installing blower, install a properly grounded, 120 volt three-prong electrical outlet at fireplace location if an outlet is not there. If possible, locate outlet so cabinet mantel will cover it when installed (see Figure 9).
3. Install gas piping to fireplace location. This installation includes an approved flexible gas line (if allowed by local codes) after the equipment shutoff valve. The flexible gas line must be the last item installed on the gas piping. See *Installing Gas Piping to Fireplace Location*, page 13.
4. Place hearth base accessory against wall at installation location. Cut an access hole in hearth top to run flexible gas line to fireplace (see Figure 9). Make sure to locate access hole so cabinet mantel will cover it when installed. **Note:** You can secure base to floor using wood screws. Countersink screw heads and putty over.
5. Route flexible gas line through access hole in hearth base.
6. Center cabinet mantel on hearth base (see Figure 10). Make sure mantel is flush against wall.
7. Break off nailing flanges (see Figure 11) with hammer or pliers.

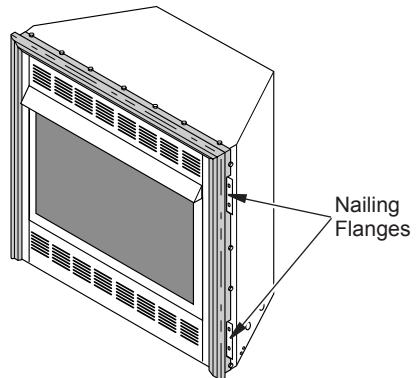


**Figure 9 - Placing Hearth Base  
Accessory Against Wall**

8. Place cardboard or other protective material on top of hearth base. Carefully set fireplace on protective material, with back of fireplace inside mantel opening.
9. Attach flexible gas line from fireplace gas regulator to gas supply. See *Connecting Fireplace to Gas Supply*, page 15.
10. If blower is installed, route blower electrical cord through access holes in either side of fireplace. **Note:** Bushing may be moved if necessary. Plug electrical cord into electrical outlet.
11. Carefully insert fireplace into cabinet mantel. Be careful not to scratch or damage hearth base, cabinet mantel or any laminate trim on hearth base. Remove protective material from top of hearth base and from front of fireplace (if any). **Note:** You can secure fireplace to hearth or floor. Open lower louver. Locate screw holes in bottom of base. Tighten wood screws through these holes and into hearth or floor.
12. Check all gas connections for leaks. See *Checking Gas Connections*, page 16.



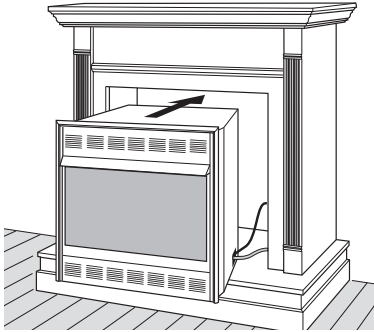
**Figure 10 - Installing Cabinet Mantel**



**Figure 11 - Location of Nailing Flanges**

## INSTALLATION

*Continued*



**Figure 12 - Inserting Fireplace Into Cabinet Mantel**

### BUILT-IN FIREPLACE INSTALLATION

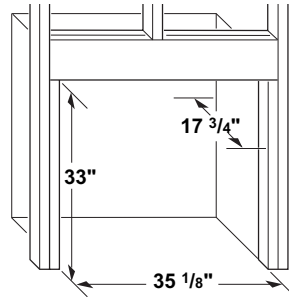
Built-in installation of this fireplace involves installing fireplace into a framed-in enclosure. This makes the front of fireplace flush with wall. If installing a mantel above the fireplace, you must follow the clearances shown in Figure 18, page 13. Follow the instructions below to install the fireplace in this manner.

	Actual	Framing
Height	32 <sup>3</sup> / <sub>8</sub> "	33"
Front Width	34 <sup>5</sup> / <sub>16</sub> "	35 <sup>1</sup> / <sub>8</sub> "
Depth	16 <sup>11</sup> / <sub>16</sub> "	17 <sup>3</sup> / <sub>4</sub> "

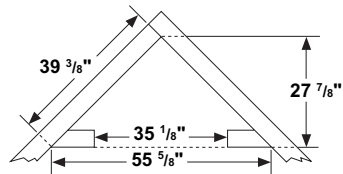
**⚠ WARNING: A qualified electrician must connect electrical wiring to duplex outlet for built-in installation. Follow all local codes.**

1. Frame in rough opening. Use dimensions shown in Figure 13 for the rough opening. If installing in a corner, use dimensions shown in Figure 14 for the rough opening. The height is 33" which is the same as the wall opening above.
2. If using blower, install duplex outlet to the right support bracket in the bottom of firebox (see Figure 15). See *Accessories*, page 34. If not using blower, go to step 7.
3. Route wires from electrical box through smallest hole in outer casing using strain relief fitting provided (see Figure 15).

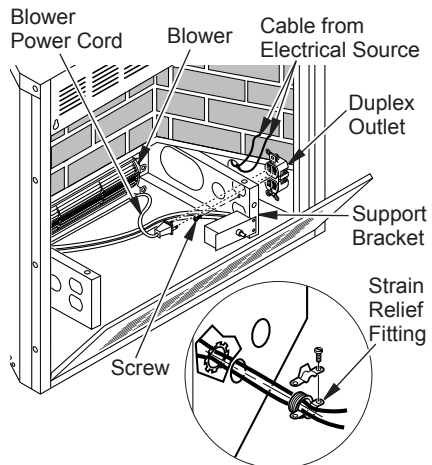
4. Connect wires from the electrical box to duplex outlet. Match wire colors to those indicated on duplex outlet. Be sure to connect ground wire.
5. Install shield to end of right support bracket and behind the firebox wrapper with 2 screws provided (see Figure 16, page 12).
6. Plug blower cord into duplex outlet.
7. Replace bottom of firebox and reconnect remote receiver module to valve.



**Figure 13 - Rough Opening for Installing in Wall**



**Figure 14 - Rough Opening for Installing in Corner**

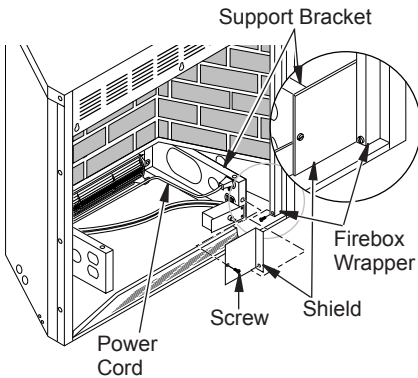


**Figure 15 - Connecting Duplex Outlet**

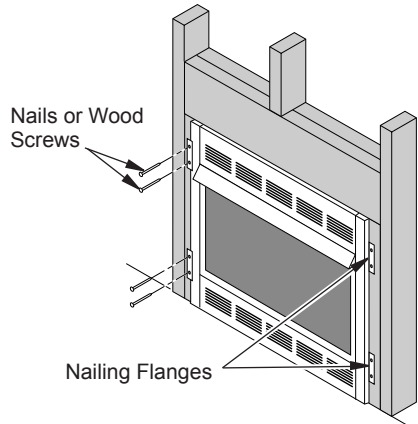
## INSTALLATION

### Continued

8. Install gas piping to fireplace location. This installation includes an approved flexible gas line (if allowed by local codes) after the equipment shutoff valve. The flexible gas line must be the last item installed on the gas piping. See *Installing Gas Piping to Fireplace Location*, page 13.
9. Carefully set fireplace in front of rough opening with back of fireplace inside wall opening.
10. Attach flexible gas line to gas supply. See *Connecting Fireplace to Gas Supply*, page 15.
11. Plug electrical cord into electrical outlet installed in step 2 if using blower.
12. Carefully insert fireplace into rough opening.
13. Attach fireplace to wall studs using nails or wood screws through holes in nailing flange (see Figure 17).
14. Check all gas connections for leaks. See *Checking Gas Connections*, page 16.
15. Install trim after final finishing and/or painting of wall (see Figure 7, page 9).



**Figure 16 - Installing Shield to Support Bracket**



**Figure 17 - Attaching Fireplace to Wall Studs**

### Mantel Clearances for Built-In Installation

If placing mantel above built-in fireplace, you must meet minimum clearance between mantel shelf and top of fireplace opening.

**NOTICE: If your installation does not meet the minimum clearances shown, you must do one of the following:**

- raise the mantel to an acceptable height
- remove the mantel

**NOTICE: Surface temperatures of adjacent walls and mantels become hot during operation. Walls and mantels above the firebox may become hot to the touch. If installed properly, these temperatures meet the requirement of the national product standard. Follow all minimum clearances shown in this manual.**

# INSTALLATION

Continued

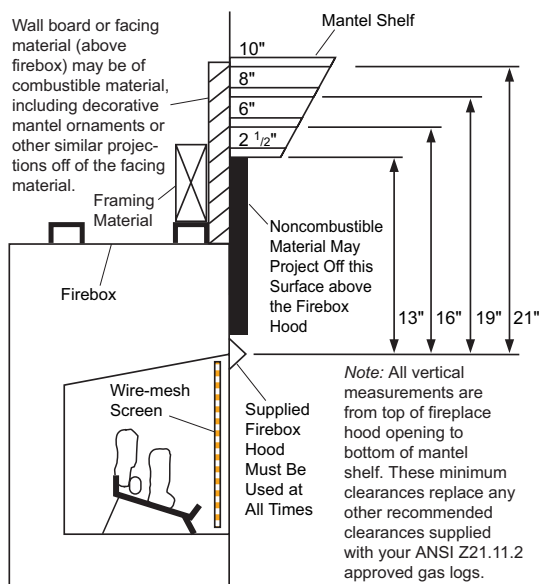


Figure 18 - Minimum Mantel Clearances for Built-In Installation

## INSTALLING GAS PIPING TO FIREPLACE LOCATION

**⚠ WARNING:** This appliance requires a 1/2" NPT (National Pipe Thread) inlet connection to the pressure regulator.

**⚠ WARNING:** A qualified service person must connect fireplace to gas supply. Follow all local codes.

**⚠ CAUTION:** Never connect propane/LP fireplace directly to the propane/LP supply. This fireplace requires an external regulator (not supplied). Install the external regulator between the fireplace and propane/LP supply.

**⚠ WARNING:** Never connect natural gas fireplace to private (non-utility) gas wells. This gas is commonly known as wellhead gas.

### Installation Items Needed

Before installing fireplace, make sure you have the items listed below.

- external regulator for propane/LP unit only (supplied by installer)
- piping (check local codes)
- sealant (resistant to propane/LP gas)
- equipment shutoff valve \*
- test gauge connection \*
- sediment trap (optional)
- tee joint
- pipe wrench
- approved flexible gas line with gas connector (if allowed by local codes) (not provided)

\* A CSA design-certified equipment shutoff valve with 1/8" NPT tap is an acceptable alternative to test gauge connection. Purchase the optional CSA design-certified equipment shutoff valve from your dealer. See *Accessories*, page 34.

## INSTALLATION

### Continued

For propane/LP units, the installer must supply an external regulator. The external regulator will reduce incoming gas pressure. You must reduce incoming gas pressure to between 11 and 14 inches of water. If you do not reduce incoming gas pressure, heater regulator damage could occur. Install external regulator with the vent pointing down as shown in Figure 19. Pointing the vent down protects it from freezing rain or sleet.

**⚠ CAUTION: Use only new, black iron or steel pipe. Internally-tinned copper tubing may be used in certain areas. Check your local codes. Use pipe of 1/2" diameter or greater to allow proper gas volume to fireplace. If pipe is too small, undue loss of volume will occur.**

Installation must include an equipment shutoff valve, union and plugged 1/8" NPT tap. Locate NPT tap within reach for test gauge hook up. NPT tap must be upstream from fireplace (see Figure 20).

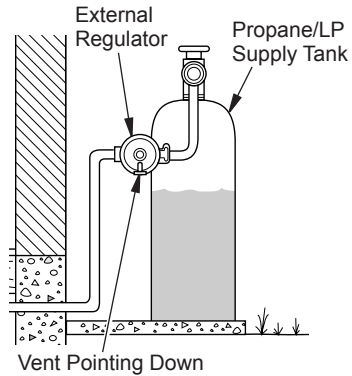
**IMPORTANT:** Install equipment shutoff valve in an accessible location. The equipment shutoff valve is for turning on or shutting off the gas to the appliance.

Check your building codes for any special requirements for locating equipment shutoff valve to fireplaces.

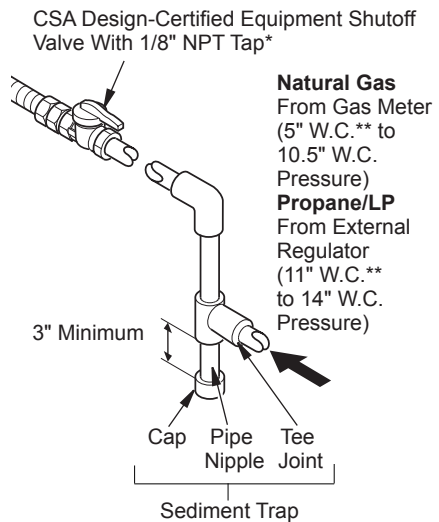
Apply pipe joint sealant lightly to male NPT threads. This will prevent excess sealant from going into pipe. Excess sealant in pipe could result in clogged fireplace valves. Never use sealant on flare threads.

**⚠ WARNING: Use pipe joint sealant that is resistant to liquid petroleum (LP) gas.**

We recommend that you install a sediment trap in supply line as shown in Figure 20. Locate sediment trap where it is within reach for cleaning. Install in piping system between fuel supply and fireplace. Locate sediment trap where trapped matter is not likely to freeze. A sediment trap traps moisture and contaminants. This keeps them from going into fireplace gas controls. If sediment trap is not installed or is installed wrong, fireplace may not run properly.



**Figure 19 - External Regulator on Propane/LP Supply Tank with Vent Pointing Down**



**Figure 20 - Gas Connection**

\* Purchase the optional CSA design-certified equipment shutoff valve from your dealer. See *Accessories*, page 34.

\*\* Minimum inlet pressure for purpose of input adjustment.

# INSTALLATION

*Continued*

## CONNECTING FIREPLACE TO GAS SUPPLY

### Installation Items Needed

- 5/16" hex socket wrench or nut-driver
  - Phillips screwdriver
  - sealant (resistant to propane/LP gas, not provided)
1. Remove two screws that hold fireplace screen in place for shipping. These screws are located near top of screen. Discard screws. Lift fireplace screen up and pull out to remove.
  2. Open lower louver door. Carefully pull straight out on the wire harnesses attached to right side and front of remote receiver module (see Figure 21).
  3. Remove screws that attach log base assembly to fireplace (see Figure 21). Carefully lift up log base assembly and remove from fireplace (see Figure 21).

**Note:** If adding the G8000A series brick liner accessory, install it now. Follow instructions in G8000A accessory kit.

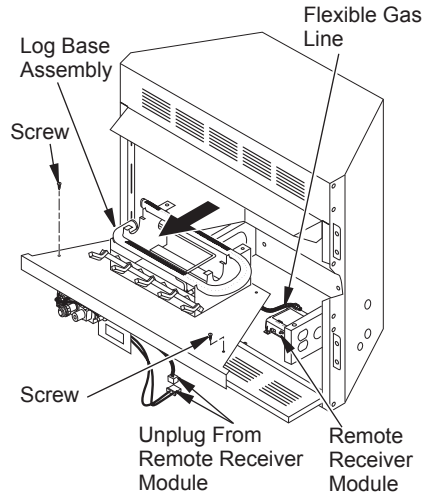
**CAUTION:** Do not pick up log base assembly by burner. This could damage burner. Only handle base by grates.

4. Route gas line (provided by installer) from equipment shutoff valve to fireplace. Route flexible gas supply line through one of the access holes.

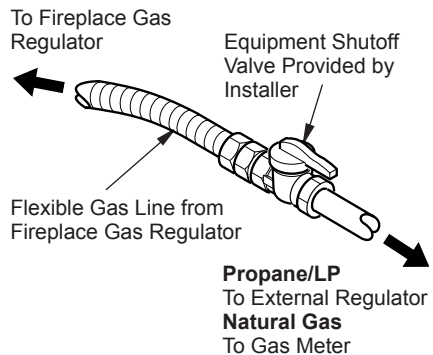
**NOTICE:** Most building codes do not permit concealed gas connections. A flexible gas line is provided to allow accessibility from the fireplace (see Figure 22). The flexible gas supply line connection to the equipment shutoff valve should be accessible.

5. Attach the flexible gas line to gas supply (see Figure 22). Check tightness of flexible gas line attached to gas regulator of fireplace (see Figure 22).
6. Check all gas connections for leaks. See *Checking Gas Connections*, page 16.

7. Replace log base assembly back into fireplace. Feed flexible gas line into fireplace base area while replacing log base assembly. Make sure the entire flexible gas line is in fireplace base area. Reattach log base assembly to fireplace with screws removed in step 2.



**Figure 21 - Removing Log Base Assembly From Fireplace**



**Figure 22 - Attaching Flexible Gas Lines Together**

# INSTALLATION

*Continued*

## CHECKING GAS CONNECTIONS

**⚠ WARNING:** Test all gas piping and connections, internal and external to unit, for leaks after installing or servicing. Correct all leaks at once.

**⚠ WARNING:** Never use an open flame to check for a leak. Apply a noncorrosive leak detection fluid to all joints. Bubbles forming show a leak. Correct all leaks at once.

**⚠ CAUTION:** Make sure external regulator has been installed between propane/LP supply and fireplace. See guidelines under *Connecting Fireplace to Gas Supply*, page 15.

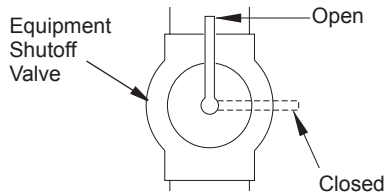
## PRESSURE TESTING GAS SUPPLY PIPING SYSTEM

**Test Pressures In Excess Of 1/2 PSIG (3.5 kPa)**

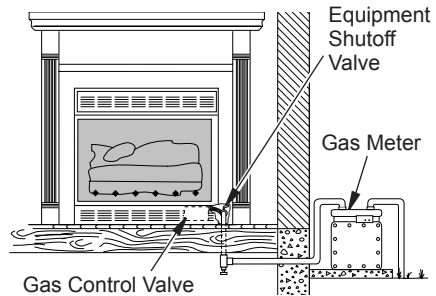
1. Disconnect fireplace with its appliance main gas valve (control valve) and equipment shutoff valve from gas supply piping system. Pressures in excess of 1/2 psig will damage fireplace regulator.
2. Cap off open end of gas pipe where equipment shutoff valve was connected.
3. Pressurize supply piping system by either opening propane/LP supply tank valve for propane/LP gas or opening main gas valve located on or near gas meter for natural gas or using compressed air.
4. Check all joints of gas supply piping system. Apply noncorrosive leak detection fluid to all joints. Bubbles forming show a leak.
5. Correct all leaks at once.
6. Reconnect fireplace and equipment shutoff valve to gas supply. Check reconnected fittings for leaks.

**Test Pressures Equal To or Less Than 1/2 PSIG (3.5 kPa)**

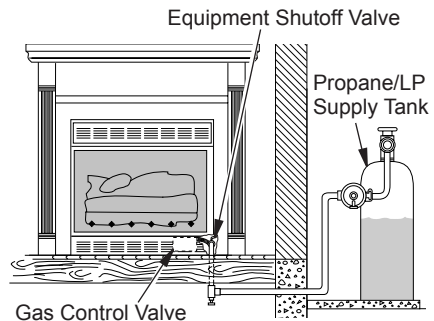
1. Close equipment shutoff valve (see Figure 23).
2. Pressurize supply piping system by either opening propane/LP supply tank valve for propane/LP gas or opening main gas valve located on or near gas meter for natural gas or using compressed air.
3. Check all joints from gas meter to equipment shutoff valve for natural gas or propane/LP supply to equipment shutoff valve for propane/LP (see Figures 24 or 25). Apply noncorrosive leak detection fluid to all joints. Bubbles forming show a leak.
4. Correct all leaks at once.



**Figure 23 - Equipment Shutoff Valve**



**Figure 24 - Checking Gas Joints for Natural Gas**



**Figure 25 - Checking Gas Joints for Propane/LP Gas**



# INSTALLATION

## Continued

### Pressure Testing Fireplace Gas Connections

1. Open equipment shutoff valve (see Figure 23, page 16).
2. Open main gas valve located on or near gas meter for natural gas or open propane/LP supply tank valve.
3. Make sure control knob of fireplace is in the OFF position.
4. Check all joints from equipment shutoff valve to gas control valve (see Figures 24 or 25, page 16). Apply noncorrosive leak detection fluid to all joints. Bubbles forming show a leak.
5. Correct all leaks at once.
6. Light fireplace (see *Operating Fireplace*, page 20.) Check all other internal joints for leaks.
7. Turn off fireplace (see *To Turn Off Gas to Appliance*, page 21).

### INSTALLING LOGS

**CAUTION:** Do not remove the data plates attached to the heater base assembly. The data plates contain important warranty and safety information.

**WARNING:** Failure to position the parts in accordance with these diagrams or failure to use only parts specifically approved with this heater may result in property damage or personal injury.

**WARNING:** After installation and periodically thereafter, check to ensure that no flame comes in contact with any log. With the heater set to High, check to see if flame contact any log. If so, reposition logs according to the log installation instructions in this manual. Flames contacting logs will create soot.

Each log is marked with a number. These numbers will help you identify the log when installing. It is very important to install these logs exactly as instructed. Do not modify logs. Only use logs supplied with heater.

### Models LMFP33PR and LMFP33NR

1. Place pins in rear log (#1) into holes on rear of base grate as shown in Figure 26.
2. Place middle log (#2) between front and rear of burner. The left side will rest on the left tab and the right will straddle the burner as shown in Figure 26.
3. Place front log (#3) onto grate fingers at front of base grate (see Figure 27). Make sure log seats well into grate.
4. Place left top log on left pins on logs #2 and #3, resting it on log #1 (see Figure 28, page 18).
5. Place right top log on right pins on logs #2 and #3 (see Figure 28, page 18).

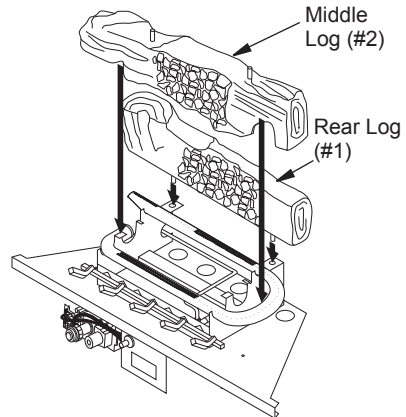


Figure 26 - Installing Rear and Middle Logs

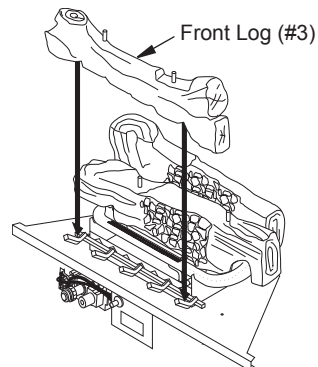
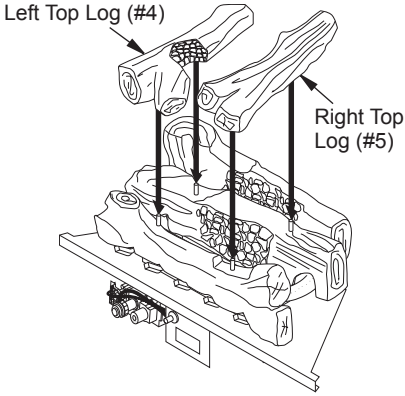


Figure 27 - Installing Front Log

# INSTALLATION

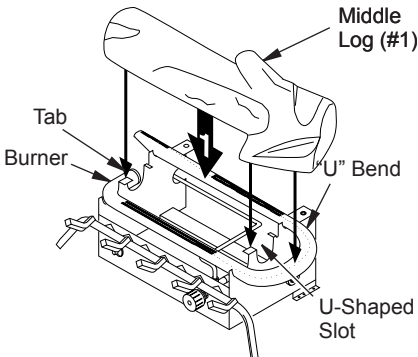
*Continued*



**Figure 28 - Installing Top Logs**

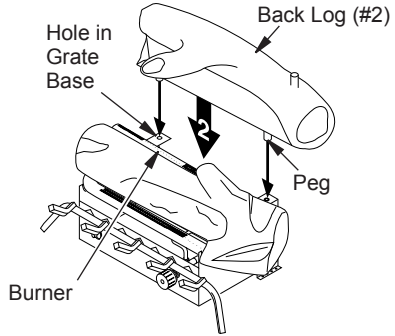
## Models LMFP33PRA and LMFP33NRA

1. Place the base of the middle log (#1) in the U-shaped slots of the grate base. The cutout on the right of the middle log should fit over the burner (see Figure 29). Make sure the front of the middle log is resting on the tabs of the grate base and the cutout area is centered over the burner "U" bend.
2. Locate pegs on the bottom of back log (#2). Slide these pegs into the holes in the grate base behind the burner (see Figure 30).
3. Locate the notches in the bottom of the front log (#3). Place the front log on the grate fingers. Make sure the notches of the front log line up with the grate fingers (see Figure 31).
4. Place crossover log (#4) onto the pin (right) on back log (#2) and into the recess of the middle log (#1) (see Figure 32).

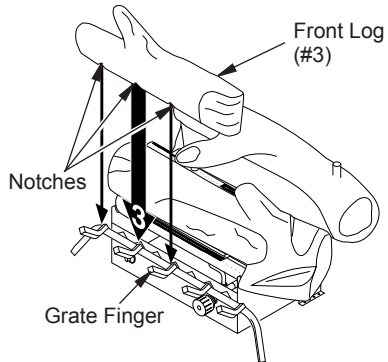


**Figure 29 - Installing Middle Log (#1)**  
(Base may vary from illustration)

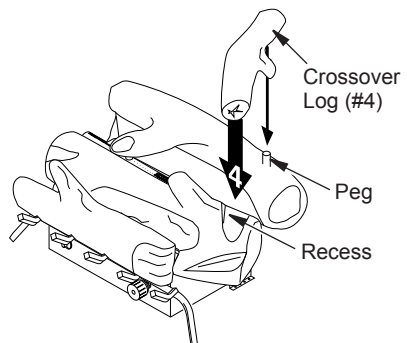
**⚠ WARNING:** You must operate this fireplace with the fireplace screen in place. Make sure fireplace screen is in place before running fireplace.



**Figure 30 - Installing Back Log (#2)**  
(Base may vary from illustration)



**Figure 31 - Installing Front Log (#3)**  
(Base may vary from illustration)



**Figure 32 - Installing Crossover Log (#4)**  
(Base may vary from illustration)

# INSTALLATION

*Continued*

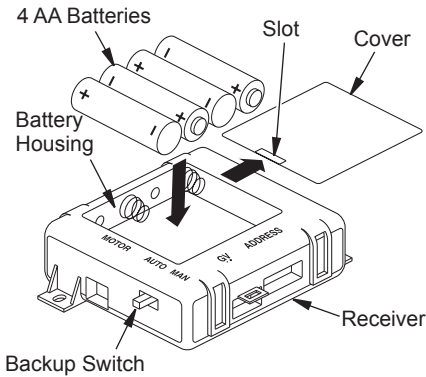
## INSTALLING BATTERIES FOR REMOTE RECEIVER AND HAND HELD REMOTE CONTROL

Four AA batteries and three AAA batteries are required to operate this heater with the wireless hand-held remote control set. Four AA batteries must be installed in the receiver and three AAA batteries in the hand-held remote control unit.

**Note:** Only use alkaline batteries.

### Installing Batteries in Receiver

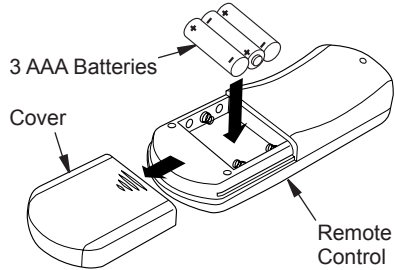
1. Locate slot on battery cover of receiver (see Figure 33). Firmly insert tool such as a small screwdriver, butter knife or dime into the slot and lift up to remove cover.
2. Insert 4 AA batteries into receiver. Positive and negative are marked inside receiver casing. **Note:** Receiver will not function if batteries are not installed correctly.
3. Slide tab on cover into receiver housing and snap cover back into place.



**Figure 33 - Installing Batteries in Receiver**

### Installing Battery into Remote


1. Remove remote cover (see Figure 34).
2. Insert 3 AAA batteries into remote control (see Figure 34). Positive and negative are marked inside remote control casing. **Note:** Remote will not function if batteries are not installed correctly.
3. Slide remote cover back into place.



**Figure 34 - Installing Batteries in Remote Control**

## OPERATING HEATER

FOR YOUR SAFETY  
READ BEFORE LIGHTING

 **WARNING:** If you do not follow these instructions exactly, a fire or explosion may result causing property damage, personal injury or loss of life.

- A. This appliance has a pilot which must be lighted by hand. When lighting the pilot, follow these instructions exactly.
- B. **BEFORE LIGHTING** smell all around the appliance area for gas. Be sure to smell next to the floor because some gas is heavier than air and will settle on the floor.
- WHAT TO DO IF YOU SMELL GAS**
- Do not try to light any appliance.
  - Do not touch any electric switch; do not use any phone in your building.
  - Immediately call your gas supplier from a neighbor's phone. Follow the gas supplier's instructions.
  - If you cannot reach your gas supplier, call the fire department.
- C. Use only your hand to push in or turn the gas control knob. Never use tools. If the knob will not push in or turn by hand, don't try to repair it, call a qualified service technician or gas supplier. Force or attempted repair may result in a fire or explosion.
- D. Do not use this appliance if any part has been under water. Immediately call a qualified service technician to inspect the appliance and to replace any part of the control system and any gas control which has been under water.


## LIGHTING INSTRUCTIONS


 **WARNING**

- If fireplace has glass doors, never operate this heater with glass doors closed. If you operate heater with doors closed, heat buildup inside fireplace will cause glass to burst. Make sure there are no obstructions across opening of fireplace.
- You must operate this heater with a fireplace screen in place. Make sure fireplace screen is closed before running heater.

**NOTICE:** During initial operation of new heater, burning logs will give off a paper-burning smell. Orange flame will also be present. Open damper or window to vent smell. This will only last a few hours.

*Note:* Home owners generally prefer to operate their heater with the chimney damper closed. This will put all the heat into the room. However, there may be times you will desire the full flames of the highest heat setting but will find the heat output excessive. You can open the chimney damper (if you have one) fully or partially to release some of the heat.

 **WARNING:** Damper handle will be hot if heater has been running.

 **WARNING:** Burners will come on automatically within one minute when the control valve is in the ON position after the pilot is lit.

# OPERATING HEATER

*Continued*

1. STOP! Read the safety information on page 20.
2. Make sure equipment shutoff valve is fully open.
3. Set remote selector switch in the AUTO position (see Figure 35).
4. Press in and turn control knob clockwise ↻ to the OFF position (see Figure 35).
5. Wait five (5) minutes to clear out any gas. Then smell for gas, including near the floor. If you smell gas, STOP! Follow "B" in the safety information on page 20. If you don't smell gas, go to the next step.
6. Press in and turn control knob counterclockwise ↻ to the PILOT position. Press in control knob for five (5) seconds (see Figure 35).

**Note:** You may be running this heater for the first time after hooking up to gas supply. If so, the control knob may need to be pressed in for 30 seconds or more. This will allow air to bleed from the gas system.

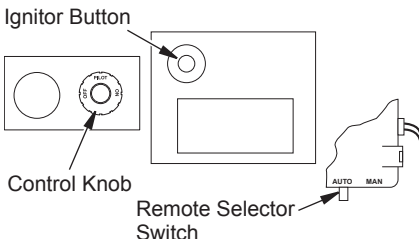
7. With control knob pressed in, press and release ignitor button. This will light pilot. The pilot is attached to the rear of the front burner. If needed, keep pressing ignitor button until pilot lights.

**Note:** If pilot does not stay lit, contact a qualified service person or gas supplier for repairs. Until repairs are made, light pilot with match. To light pilot with match, see *Manual Lighting Procedure*.

8. Keep control knob pressed in for 30 seconds after lighting pilot. After 30 seconds, release control knob.

• If control knob does not pop out when released, contact a qualified service person or gas supplier for repairs.

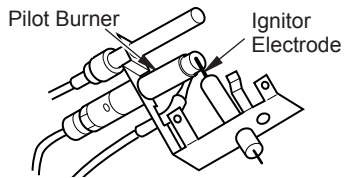
**Note:** If pilot goes out, repeat steps 4 through 8.



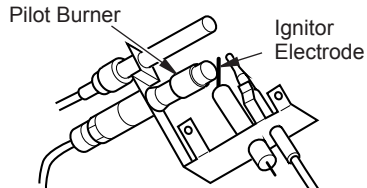
**Figure 35 - Remote Selector Switch, Control Knob and Ignitor Button**

9. Slightly push in and turn control knob counterclockwise ↻ to the ON position.
10. Press the on/off key on the remote control to turn on appliance main burner. Wait at least 5 seconds before setting desired flame height.
11. Press the up or down key until the small triangle is to the left of large flame icon at the top of LCD display (see Figure 38, page 22). Press the left or right key to set the desired flame height.

**CAUTION:** Do not try to adjust heating levels by using the equipment shutoff valve.



**Figure 36 - Pilot (Propane/LP)**



**Figure 37 - Pilot (Natural)**

## TO TURN OFF GAS TO APPLIANCE

### Shutting Off Heater

Press on/off key on remote control and turn control knob clockwise ↻ to the OFF position (see Figure 35).

### Shutting Off Burners Only (pilot stays lit)

Press the on/off key on remote control or turn control knob clockwise ↻ to the PILOT position.

## MANUAL LIGHTING PROCEDURE

1. Follow steps 1 through 7 under *Lighting Instructions*, column 1.
2. Depress control knob and light pilot with match.
3. Keep control knob pressed in for 30 seconds after lighting pilot. After 30 seconds, release control knob. Now follow steps 9 through 11 under *Lighting Instructions*.


# OPERATING HEATER

Continued

## HAND-HELD REMOTE OPERATION

**NOTICE:** You must light the pilot before using the hand-held remote control unit. See *Lighting Instructions*, page 20.

When the appliance and the remote control are switched off, the house icon with the room temperature will be displayed. When the remote control is turned on, other icons will be visible and the main burner of the appliance will turn on.

1. Turn control knob clockwise  to the ON position (see Figure 35, page 21).
2. Press the ON button on remote control (see Figure 38). Wait 5 seconds to send a command to appliance.

**Note:** An acoustic signal will be heard that confirms the reception of the command sent from the remote control.

### Setting Flame Height

Press the up or down key until the small triangle is to the left of large flame icon at the top of LCD display (see Figure 38). Press the left or right key to set the desired flame height. Six flame levels are available from 1 (minimum) to 6 (maximum).

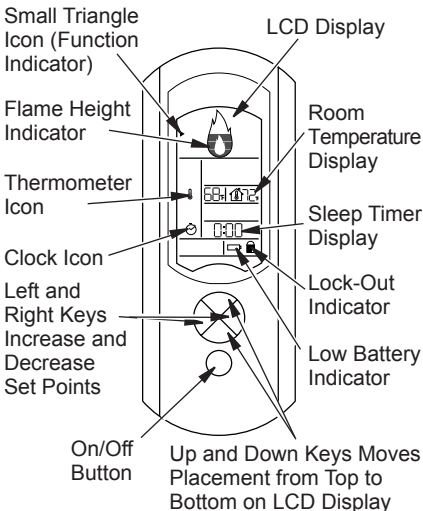


Figure 38 - Remote Control

### Setting Room Temperature

Press the up or down key until the small triangle is to the left of the thermometer icon (see Figure 38). Press the left or right key to set the desired room temperature.

### Setting Timer (Sleep Function)

Press the up or down key until the small triangle is to the left of the clock icon (see Figure 38). Press the left or right key to set the desired sleep time. Maximum sleep time is 90 minutes, in 15 minute increments. When desired time is set, press the up or down key to start the timer. When the desired time has elapsed, the appliance will automatically switch off.

### Child Safety Lock-Out

To lock the remote control keys, press the On/Off key then immediately press the up key (see Figure 38). The lock-out function is active when the lock icon is lit. Repeat key sequence to unlock keys.

### Low Battery Detection and Backup

A battery icon will be displayed on the LCD display when batteries are low in the remote control (see Figure 38).

When the receiver detects a low battery condition;

- Three acoustic “beeps” are generated from the receiver
- Appliance is turned off and will go to the maximum flame height
- Execution of commands is inhibited until batteries are replaced

When batteries are low, it is not possible to turn on the appliance with the remote control. Appliance can be turned on or off manually by setting the backup switch of the receiver to MAN position (see Figure 35, page 21). Remote control and receiver will restart normal operation after batteries are replaced. See *Installing Batteries for Remote Receiver and Hand Held Remote Control*, page 19.

### Timeout

If appliance is turned on and no command is sent to the receiver for 24 hours, appliance will automatically shut down. Commands sent after shutdown will be executed normally.

## INSPECTING BURNERS

Check pilot flame pattern and burner flame patterns often.

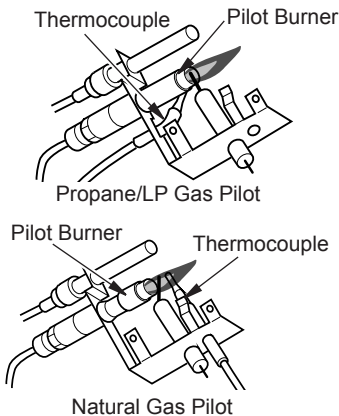
### PILOT FLAME PATTERN

Figure 39 shows a correct pilot flame pattern. Figure 40 shows an incorrect pilot flame pattern. The incorrect pilot flame is not properly heating the thermocouple. When the thermocouple cools, the heater will shut down.

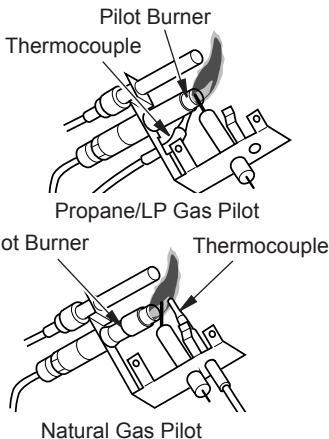
If pilot flame pattern is incorrect, as shown in Figure 40

- turn heater off (see *To Turn Off Gas to Appliance*, page 21)
- see *Troubleshooting*, page 25

**Note:** The pilot flame on a natural gas unit will have a slight curve, but flame should be blue and have no yellow or orange color.



**Figure 39 - Correct Pilot Flame Pattern**



**Figure 40 - Incorrect Pilot Flame Pattern**

### BURNER PRIMARY AIR HOLES

Air is drawn into the burner through the holes in the fitting at the burner entrance. These holes may become blocked with dust or lint. Periodically inspect these holes for any blockage and clean if needed. Blocked air holes will create soot.

### MAIN BURNER

Periodically inspect all burner flame holes with the fireplace running. All slotted burner flame holes should be open with yellow flame present. All round burner flame holes should be open with a small blue flame present. Some burner flame holes may become blocked by debris or rust, with no flame present. If so, turn off fireplace and let cool. Remove blockage. Blocked burner flame holes will create soot.

### BURNER FLAME PATTERN

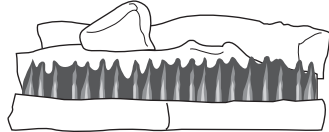
**WARNING:** If yellow tipping occurs, your fireplace could produce increased levels of carbon monoxide.

**NOTICE:** Do not mistake orange flames with yellow tipping. Dirt or other fine particles enter the fireplace and burn causing brief patches of orange flame.

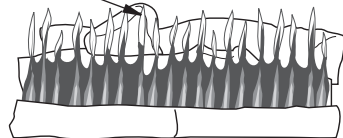
Figure 41 shows a correct burner flame pattern. Figure 42 shows an incorrect burner flame pattern. The incorrect burner flame pattern shows the flame higher consistently higher than 1 inch above the logs.

If burner flame pattern is incorrect, as shown in Figure 42

- turn heater off (see *To Turn Off Gas To Appliance*, page 21)
- see *Troubleshooting*, page 25



**Figure 41 - Correct Burner Flame Pattern**  
Yellow Tipping



**Figure 42 - Incorrect Burner Flame Pattern**

## CLEANING AND MAINTENANCE

**⚠ WARNING:** Turn off fireplace and let cool before cleaning.

**⚠ CAUTION:** You must keep control areas, burner and circulating air passageways of fireplace clean. Inspect these areas of fireplace before each use. Have fireplace inspected yearly by a qualified service person. Fireplace may need more frequent cleaning due to excessive lint from carpeting, bedding material, pet hair, etc.

**⚠ WARNING:** Failure to keep the primary air opening(s) of the burner(s) clean may result in sooting and property damage.

### BURNER INJECTOR HOLDER AND PILOT AIR INLET HOLE

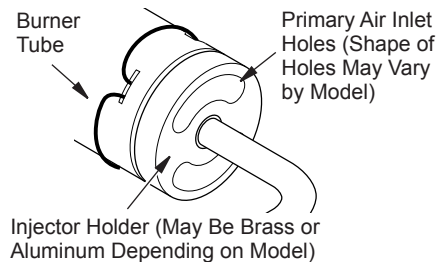
The primary air inlet holes allow the proper amount of air to mix with the gas. This provides a clean burning flame. Keep these holes clear of dust, dirt, lint and pet hair. Clean these air inlet holes prior to each heating season. Blocked air holes will create soot. We recommend that you clean the unit every three months during operation and have heater inspected yearly by a qualified service person.

We also recommend that you keep the burner tube and pilot assembly clean and free of dust and dirt. To clean these parts we recommend using compressed air no greater than 30 PSI. Your local computer store, hardware store or home center may carry compressed air in a can. You can use a vacuum cleaner in the blow position. If using compressed air in a can, please follow the directions on the can. If you don't follow directions on the can, you could damage the pilot assembly.

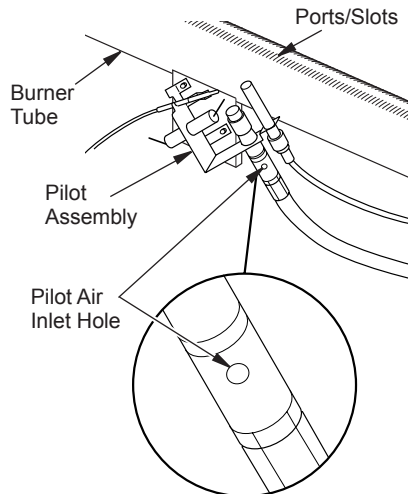
1. Shut off the unit, including the pilot. Allow the unit to cool for at least thirty minutes.
2. Inspect burner, pilot and primary air inlet holes on injector holder for dust and dirt (see Figures 43 and 44).
3. Blow air through the ports/slots and holes in the burner.

4. Check the injector holder located at the end of the burner tube again. Remove any large particles of dust, dirt, lint or pet hair with a soft cloth or vacuum cleaner nozzle.
5. Blow air into the primary air holes on the injector holder.
6. In case any large clumps of dust have now been pushed into the burner repeat steps 3 and 4.

Clean the pilot assembly also. A yellow tip on the pilot flame indicates dust and dirt in the pilot assembly. There is a small pilot air inlet hole about two inches from where the pilot flame comes out of the pilot assembly (see Figure 44). With the unit off, lightly blow air through the air inlet hole. You may blow through a drinking straw if compressed air is not available.



**Figure 43 - Injector Holder On Outlet Burner Tube**



**Figure 44 - Pilot Inlet Air Hole**

### LOGS

- If you remove logs for cleaning, refer to *Installing Logs*, page 17, to properly replace logs.
- Replace log(s) if broken or chipped (dime-sized or larger).



## TROUBLESHOOTING

**⚠ WARNING:** Turn off heater and let cool before servicing. Only a qualified service person should service and repair heater.

**⚠ CAUTION:** Never use a wire, needle or similar object to clean ODS/pilot. This can damage ODS/pilot unit.

*Note:* All troubleshooting items are listed in order of operation.

OBSERVED PROBLEM	POSSIBLE CAUSE	REMEDY
When ignitor button is pressed, there is no spark at ODS/pilot	1. Ignitor electrode not connected to ignitor cable	1. Reconnect ignitor cable
	2. Ignitor cable pinched or wet	2. Free ignitor cable if pinched by any metal or tubing. Keep ignitor cable dry
	3. Piezo ignitor nut is loose	3. Tighten nut holding piezo ignitor to base panel of log set. Nut is located behind base panel
	4. Broken ignitor cable	4. Replace ignitor cable
	5. Bad piezo ignitor	5. Replace piezo ignitor
	6. Ignitor electrode positioned wrong	6. Replace pilot assembly
	7. Ignitor electrode broken	7. Replace pilot assembly
When ignitor button is pressed, there is spark at ODS/pilot but no ignition	1. Gas supply turned off or equipment shutoff valve closed	1. Turn on gas supply or open equipment shutoff valve
	2. Control knob not in PILOT position	2. Turn control knob to PILOT position
	3. Control knob not pressed in while in PILOT position	3. Press in control knob while in PILOT position
	4. Air in gas lines when installed	4. Continue holding down control knob. Repeat igniting operation until air is removed
	5. Depleted gas supply (propane/LP only)	5. Contact local propane/LP gas company
	6. ODS/pilot is clogged	6. Clean ODS/pilot (see <i>Cleaning and Maintenance</i> , page 24) or replace ODS/pilot assembly
	7. Gas regulator setting is not correct	7. Replace gas regulator

---

## TROUBLESHOOTING

*Continued*

OBSERVED PROBLEM	POSSIBLE CAUSE	REMEDY
ODS/pilot lights but flame goes out when control knob is released	1. Control knob not fully pressed in	1. Press in control knob fully
	2. Control knob not pressed in long enough	2. After ODS/pilot lights, keep control knob pressed in 30 seconds
	3. Equipment shutoff valve not fully open	3. Fully open equipment shutoff valve
	4. Pilot flame not touching thermocouple, which allows thermocouple to cool, causing pilot flame to go out. This problem could be caused by one or both of the following: A) Low gas pressure B) Dirty or partially clogged ODS/pilot	4. A) Contact local natural or propane/LP gas company
		B) Clean ODS/pilot (see <i>Cleaning and Maintenance</i> , page 24) or replace ODS/pilot assembly
	5. Thermocouple connection loose at control valve	5. Hand tighten until snug, then tighten 1/4 turn more
	6. Thermocouple damaged	6. Replace pilot assembly
7. Control valve damaged	7. Replace control valve	
Burner does not light after ODS/pilot is lit	1. Inlet gas pressure is too low	1. Contact local natural or propane/LP gas company
	2. Burner orifice(s) clogged	2. Clean burner(s) (see <i>Cleaning and Maintenance</i> , page 24) or replace burner orifice(s)
	3. Thermopile leads disconnected or improperly connected	3. Reconnect leads (see <i>Wiring Diagram</i> , page 29)
	4. Burner will not come on in remote position	4. Replace battery in transmitter and receiver
Delayed ignition of one or both burners	1. Manifold pressure is too low	1. Contact local natural or propane/LP gas company
	2. Burner orifice(s) clogged	2. Clean burner(s) (see <i>Cleaning and Maintenance</i> , page 24) or replace burner orifice(s)
Burner backfiring during combustion	1. Burner orifice is clogged or damaged	1. Clean burner (see <i>Cleaning and Maintenance</i> , page 24) or replace burner orifice(s)
	2. Damaged burner	2. Replace damaged burner
	3. Gas regulator defective	3. Replace gas regulator

---

## TROUBLESHOOTING

*Continued*

<b>OBSERVED PROBLEM</b>	<b>POSSIBLE CAUSE</b>	<b>REMEDY</b>
Slight smoke or odor during initial operation	1. Not enough air	1. Check burner for dirt and debris. If found, clean burner (see <i>Cleaning and Maintenance</i> , page 24)
Moisture/condensation noticed on windows	2. Gas regulator defective 3. Residues from manufacturing processes and logs curing	2. Replace gas control 3. Problem will stop after a few hours of operation
Heater produces a whistling noise when burners are lit	1. Not enough combustion/ventilation air	1. Refer to <i>Air for Combustion and Ventilation</i> requirements (page 5)
	1. Turning control knob to HI position when burners are cold 2. Air in gas line 3. Air passageways on heater blocked 4. Dirty or partially clogged burner orifice(s)	1. Turn control knob to LO position and let warm up for a minute 2. Operate burners until air is removed from line. Have gas line checked by local natural or propane/LP gas company 3. Observe minimum installation clearances (see page 9) 4. Clean burners (see <i>Cleaning and Maintenance</i> , page 24) or replace burner orifice(s)
White powder residue forming within burner box or on adjacent walls or furniture	1. When heated, vapors from furniture polish, wax, carpet cleaners, etc. may turn into white powder residue	1. Turn heater off when using furniture polish, wax, carpet cleaners or similar products
Remote does not function	1. Battery is not installed. Battery power is low	1. Replace 9-volt batteries in receiver and remote control
Fireplace produces a clicking/ticking noise just after burner is lit or shut off	1. Metal expanding while heating or contracting while cooling	1. This is normal with most heaters. If noise is excessive, contact qualified service person

# TROUBLESHOOTING

*Continued*



**WARNING: If you smell gas**

- **Shut off gas supply.**
- **Do not try to light any appliance.**
- **Do not touch any electrical switch; do not use any phone in your building.**
- **Immediately call your gas supplier from a neighbor's phone. Follow the gas supplier's instructions.**
- **If you cannot reach your gas supplier, call the fire department.**

*IMPORTANT:* Operating fireplace where impurities in air exist may create odors. Cleaning supplies, paint, paint remover, cigarette smoke, cements and glues, new carpet or textiles, etc., create fumes. These fumes may mix with combustion air and create odors. These odors will disappear over time.

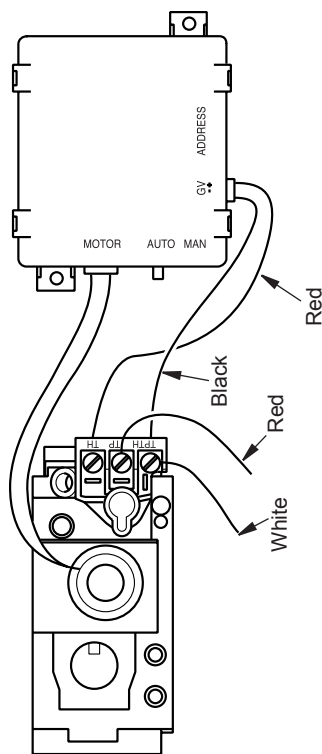
OBSERVED PROBLEM	POSSIBLE CAUSE	REMEDY
Fireplace produces unwanted odors	<ol style="list-style-type: none"> <li>1. Heater burning vapors from paint, hair spray, glues, cleaners, chemicals, new carpet, etc. (See <i>IMPORTANT</i> statement above)</li> <li>2. Low fuel supply (propane/LP only)</li> <li>3. Gas leak. <b>See Warning statement above</b></li> </ol>	<ol style="list-style-type: none"> <li>1. Open window to ventilate room. Stop using odor causing products while heater is running</li> <li>2. Refill supply tank (propane/LP only)</li> <li>3. Locate and correct all leaks (see <i>Checking Gas Connections</i>, page 16)</li> </ol>
Fireplace shuts off in use (ODS operates)	<ol style="list-style-type: none"> <li>1. Not enough fresh air is available</li> <li>2. Low line pressure</li> <li>3. ODS/pilot is partially clogged</li> </ol>	<ol style="list-style-type: none"> <li>1. Open window and/or door for ventilation</li> <li>2. Contact local natural or propane/LP gas company</li> <li>3. Clean ODS/pilot (see <i>Cleaning and Maintenance</i>, page 24)</li> </ol>
Gas odor even when control knob is in OFF position	<ol style="list-style-type: none"> <li>1. Gas leak. <b>See Warning statement above</b></li> <li>2. Control valve or gas control defective</li> </ol>	<ol style="list-style-type: none"> <li>1. Locate and correct all leaks (see <i>Checking Gas Connections</i>, page 16)</li> <li>2. Replace control valve or gas control</li> </ol>
Gas odor during combustion	<ol style="list-style-type: none"> <li>1. Foreign matter between control valve and burner</li> <li>2. Gas leak. <b>See Warning statement above</b></li> </ol>	<ol style="list-style-type: none"> <li>1. Take apart gas tubing and remove foreign matter</li> <li>2. Locate and correct all leaks (see <i>Checking Gas Connections</i>, page 16)</li> </ol>
Dark residue on logs inside of their fireplace <i>Note:</i> After removing all causes of residue deposits, completely clean fireplace and appliance off residue before reusing appliance	<ol style="list-style-type: none"> <li>1. Improper log placement</li> <li>2. Drafts or other air currents affecting flame pattern</li> <li>3. Air holes at burner inlet blocked</li> <li>4. Burner flame holes blocked</li> </ol>	<ol style="list-style-type: none"> <li>1. Properly locate logs (see <i>Installing Logs</i>, page 17)</li> <li>2. Eliminate source of drafts around heater</li> <li>3. Clean out air holes at burner inlet. Periodically repeat as needed</li> <li>4. Remove blockage</li> </ol>

## SPECIFICATIONS

	LMFP33NR(A)	LMFP33PR(A)
Btu (Variable)	23,000/33,000	23,000/33,000
Type Gas	Natural Gas	Propane/LP
Ignition	Piezo	Piezo
Pressure Manifold	3.5" W.C.	7.9" W.C.
Inlet Gas Pressure (in. of water)		
Maximum	10.5"	14"
Minimum*	5.5"	11"
Shipping Weight	122 lbs.	122 lbs.

\* For input adjustment

## WIRING DIAGRAM



## TECHNICAL SERVICE

You may have further questions about installation, operation or troubleshooting. If so, contact DESA Heating Products' Technical Service Department at 1-866-672-6040. When calling, please have your model and serial numbers of your heater ready.

You can also visit DESA Heating Products' technical services web site at [www.desatech.com](http://www.desatech.com).

## SERVICE HINTS

### When Gas Pressure Is Too Low

- pilot will not stay lit
- burner will have delayed ignition
- fireplace will not produce specified heat
- for propane/LP unit, propane/LP gas supply may be low

You may feel your gas pressure is too low. If so, contact your local gas supplier.

## REPLACEMENT PARTS

*Note:* Use only original replacement parts. This will protect your warranty coverage for parts replaced under warranty.

### PARTS UNDER WARRANTY

Contact authorized dealers of this product. If they can't supply original replacement part(s), call DESA Heating Products' Technical Service Department at 1-866-672-6040. When calling DESA Heating Products, have ready

- your name and address
- model and serial numbers of your fireplace
- how fireplace was malfunctioning
- type of gas used (propane/LP or natural gas)
- purchase date

Usually, we will ask you to return the part to the factory.

### PARTS NOT UNDER WARRANTY

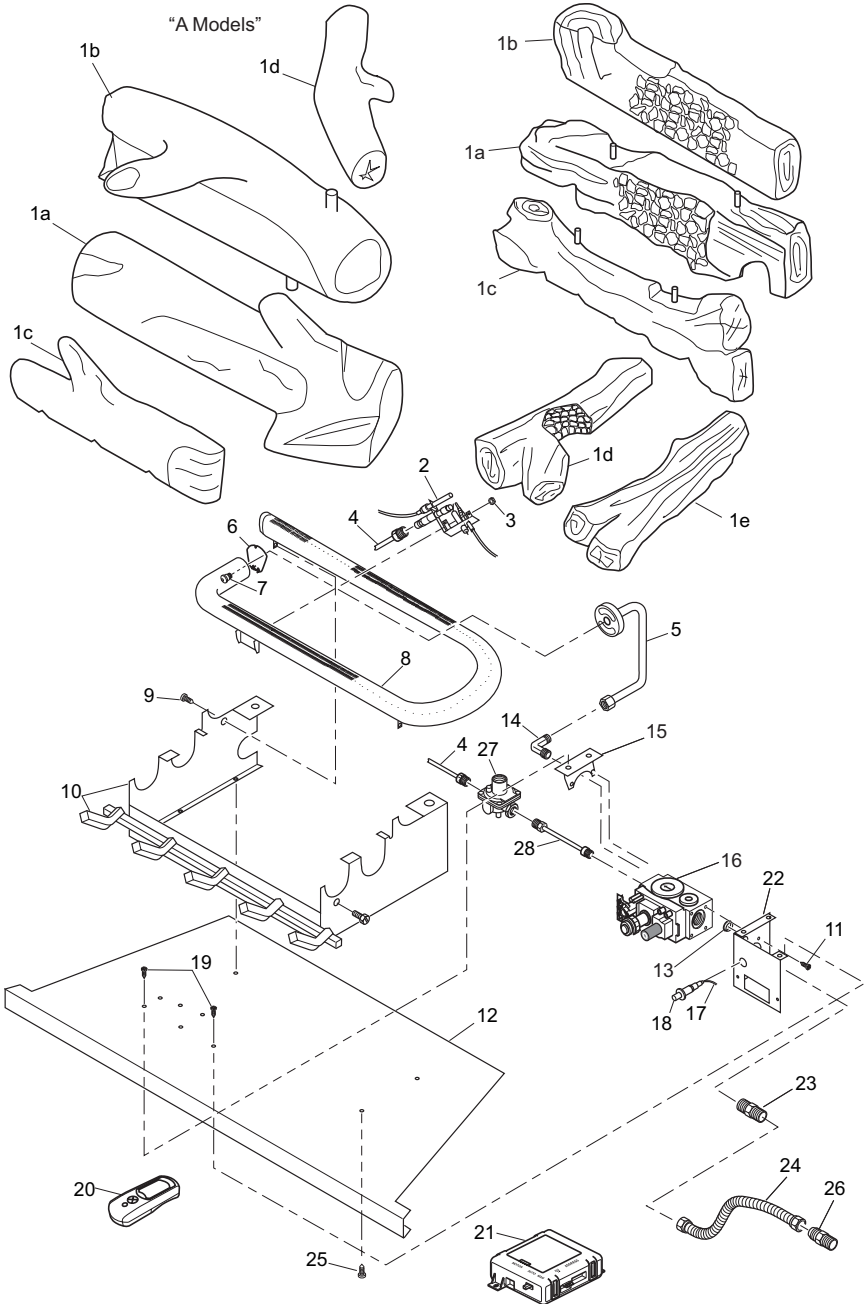
Contact authorized dealers of this product. If they can't supply original replacement part(s), call DESA Heating Products at 1-866-672-6040 for referral information. When calling DESA Heating Products, have ready

- model number of your fireplace
- the replacement part number

# ILLUSTRATED PARTS BREAKDOWN

## MODELS

LMFP33PR, LMFP33PRA, LMFP33NR AND LMFP33NRA (SHOWN)



## PARTS LIST

This list contains replaceable parts used in your fireplace. When ordering parts, follow the instructions listed under *Replacement Parts* on page 29 of this manual.

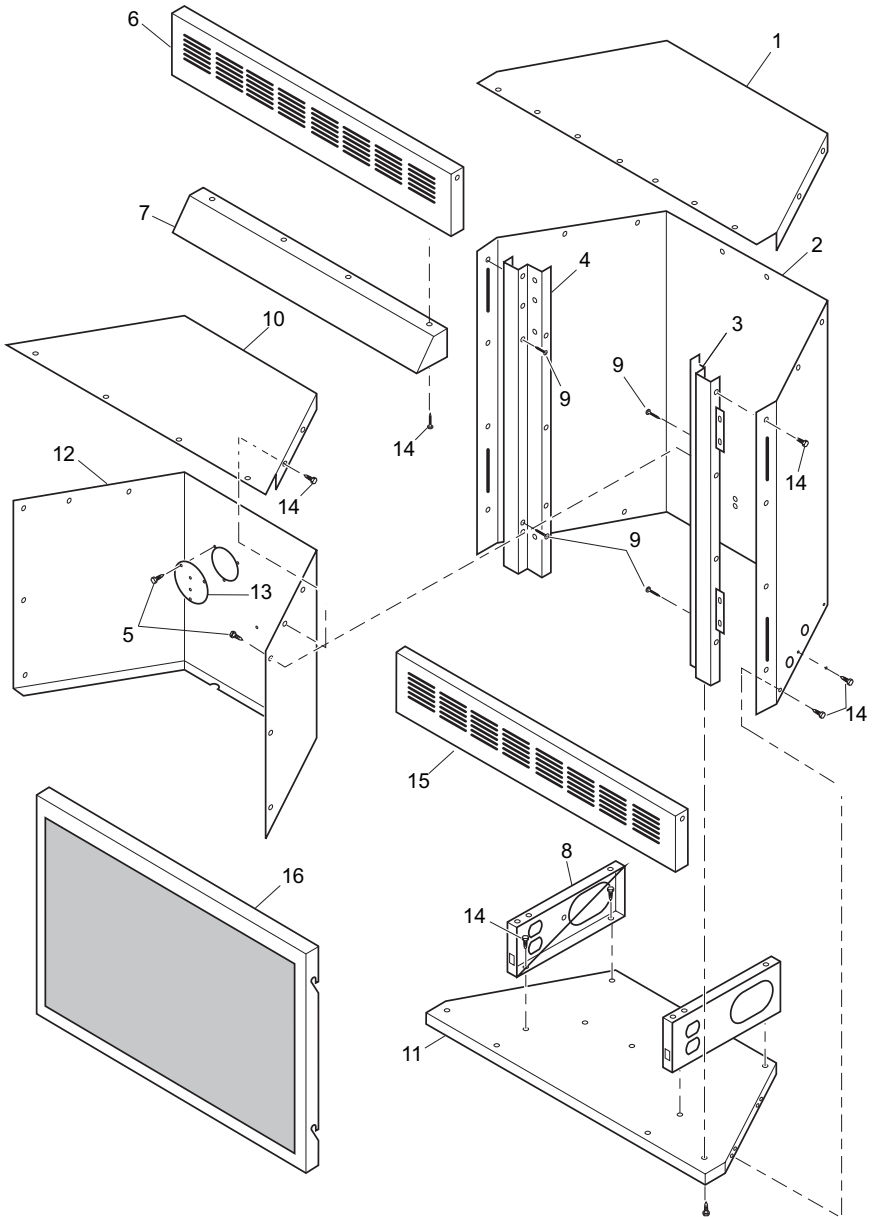
KEY NO.	PART NUMBER				DESCRIPTION	QTY.
	LMFP33PR	LMFP33PRA	LMFP33NR	LMFP33NRA		
1a	111625-03	109072-01	111625-03	109072-01	Middle Log	1
1b	111625-04	109073-01	111625-04	109073-01	Rear Log	1
1c	111625-01	109074-01	111625-01	109074-01	Front Log	1
1d	111625-07	—	111625-07	—	Left Crossover Log	1
1e	111625-05	109075-01	111625-05	109075-01	Right Crossover Log	1
2	103778-01	103778-01	103779-01	103779-01	ODS Pilot	1
3	098249-01	098249-01	098249-01	098249-01	ODS Nut	2
4	099387-09	099387-09	099387-07	099387-07	Pilot Tube	1
5	104229-03	104229-03	111331-13	111331-13	Burner Outlet Tube	1
6	111124 -01	111124-01	111124-01	111124-01	Burner Retainer Spring	1
7	099056-31	099056-31	099056-26	099056-26	Burner Orifice Injector	1
8	102772-01	102772-01	102772-01	102772-01	Burner	2
9	M11084-38	M11084-38	M11084-38	M11084-38	Screw, #8-16 x .38	4
10	104236-01CK	104236-01CK	104236-01CK	104236-01CK	Painted Base Assembly	1
11	M12461-26	M12461-26	M12461-26	M12461-26	Screw, #10-32 x 0.38	4
12	**	**	**	**	Firebox Bottom	1
13	M50104-02	M50104-02	M50104-02	M50104-02	Bushing	1
14	098265-02	098265-02	098265-02	098265-02	Elbow, Male	1
15	103782-01	103782-01	103782-01	103782-01	Valve Bracket	1
16	111440-04	111440-04	111440-03	111440-03	Gas Valve, Remote	1
17	098271-10	098271-10	098271-10	098271-10	Ignitor Cable	1
18	102445-01	102445-01	102445-01	102445-01	Piezo Ignitor	1
19	098304-01	098304-01	098304-01	098304-01	Screw	7
20	111442-02	111442-02	111442-02	111442-02	Digital Display Remote Control	1
21	111441-02	111441-02	111441-02	111441-02	Proflame Receiver	1
22	104241-01	104241-01	104241-01	104241-01	Remote Switch Bracket	1
23	097809-02	097809-02	097809-02	097809-02	Male Connector	1
24	101628-03	101628-03	101628-03	101628-03	Flexible Connector (Hose)	1
25	M11084-26	M11084-26	M11084-26	M11084-26	Screw, #10-16 x 0.38	4
26	901063-01	901063-01	901063-01	901063-01	3/8" Flare x 1/2" NPT	1
27	—	—	099918-02	099918-02	Pilot Regulator	1
28	—	—	099387-07	099387-07	Pilot Tube	1
<b>PARTS AVAILABLE — NOT SHOWN</b>						
	097555-01	097555-01	097555-01	097555-01	Caution Decal	1

\*\* Not a field replaceable part.

# ILLUSTRATED PARTS BREAKDOWN

## FIREBOX

LMFP33PR, LMFP33PRA, LMFP33NR AND LMFP33NRA





## PARTS LIST

### FIREBOX

#### LMFP33PR, LMFP33PRA, LMFP33NR AND LMFP33NRA

This list contains replaceable parts used in your fireplace. When ordering parts, follow the instructions listed under *Replacement Parts* on page 29 of this manual.

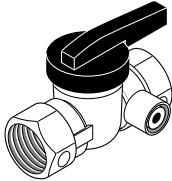
KEY			
NO.	PART NO.	DESCRIPTION	QTY.
1	101357-03	Top Outer Casing	1
2	**	Outer Casing	1
3	**	Right Front Side	1
4	**	Left Front Side	1
5	098304-01	Phillips Pan Head Screw, #10-16 x 0.38	9
6	104239-01CK	Top Front Louver	1
7	101712-03	Firebox Hood	1
8	**	Firebox Support	2
9	099230-02	Shoulder Screw	4
10	**	Firebox Top	1
11	101346-01	Outer Base	1
12	**	Firebox Wrapper	1
13	101514-01	Cover	1
14	M11084-26	Hex Screw, #10-16 x 0.38	45
15	104237-01CK	Bottom Louvered Door	1
16	101727-02	Screen Assembly	1
<b>PARTS AVAILABLE — NOT SHOWN</b>			
	101386-02	Louvered Door Hinge	2
	101784-01	Magnet Catch	2
	102307-01	Strike Plate	2

\*\* Not a field replaceable part.

## ACCESSORIES

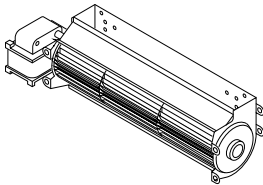
**NOTICE: All accessories may not be available for all fireplace models.**

Purchase these fireplace accessories from your local dealer. If they can not supply these accessories, call DESA Heating Products' Sales Department at 1-866-672-6040 for information. You can also write to the address listed on the back page of this manual.



### EQUIPMENT SHUTOFF VALVE GA5010

**For all models.** Equipment shutoff valve with 1/8" NPT tap. Fits 1/2" NPT pipe.



### BLOWER ACCESSORY - GA3750A AND GA3650TB SERIES

**For all models.** Manual variable control and automatic thermostat variable control. A blower will increase air flow to assist heat distribution from the firebox.

### FIREBOX BRICK LINER - G8005 Series (Not Shown)

**For all models.** Ceramic fiber firebox liner adds the look of real brick.

### INFORMATION VIDEO - 108917-01

**For all models.** A care and maintenance video is available by calling 1-866-672-6040. You may also email your request to

[productsupport@desaint.com](mailto:productsupport@desaint.com).

### CABINET MANTEL AND FULL HEARTH BASE (Not Shown)

**W32AU - Unfinished Oak, Traditional**

**W32AOS - Oak Finished, Traditional**

**CMA311WA - Painted White, Traditional with Dentil Molding**

**CMA306FA - Oak Finished, Traditional with Dentil Molding**

**CMA312FB - Dark Oak Finished, Classic W32KCSA - Cherry Finished, Neo-Classical**

**W32KPA - Painted White, Neo-Classical**

**CMA305UA - Unfinished Oak, Georgian**

**GMC90FA - Oak Finished, Georgian**

**W32DS - Red Oak Finished, Keystone**

**W32GOSA - Dark Oak Finished, Mission**

**For all models.** Three-sided perimeter trim included.

### CORNER CABINET MANTEL AND FULL HEARTH BASE (Not Shown)

**C32AU - Unfinished Oak, Traditional**

**C32AOS - Oak Finished, Traditional**

**C32HS - Dark Oak Stained, Classic**

**For all models.** Three-sided perimeter trim included.

### DUPLEX OUTLET KIT - GA3555 (Not Shown)

**For all models.** For built-in installation when accessory blowers are used.

---

## NOTES

# WARRANTY INFORMATION

## KEEP THIS WARRANTY

Model _____
Serial No. _____
Date Purchased _____

Always specify model and serial numbers when communicating with the factory.

We reserve the right to amend these specifications at any time without notice. The only warranty applicable is our standard written warranty. We make no other warranty, expressed or implied.

### LIMITED WARRANTY VENT-FREE GAS FIREPLACE

DESA Heating Products warrants this product to be free from defects in materials and components for two (2) years from the date of first purchase, provided that the product has been properly installed, operated and maintained in accordance with all applicable instructions. To make a claim under this warranty the Bill of Sale or cancelled check must be presented.

This warranty is extended only to the original retail purchaser. This warranty covers the cost of part(s) required to restore this heater to proper operating condition and an allowance for labor when provided by a DESA Heating Products Authorized Service Center. Warranty part(s) MUST be obtained through authorized dealers of this product and/or DESA Heating Products who will provide original factory replacement parts. Failure to use original factory replacement parts voids this warranty. The heater MUST be installed by a qualified installer in accordance with all local codes and instructions furnished with the unit.

This warranty does not apply to parts that are not in original condition because of normal wear and tear or parts that fail or become damaged as a result of misuse, accidents, lack of proper maintenance or defects caused by improper installation. Travel, diagnostic cost, labor, transportation and any and all such other costs related to repairing a defective heater will be the responsibility of the owner.

TO THE FULL EXTENT ALLOWED BY THE LAW OF THE JURISDICTION THAT GOVERNS THE SALE OF THE PRODUCT; THIS EXPRESS WARRANTY EXCLUDES ANY AND ALL OTHER EXPRESSED WARRANTIES AND LIMITS THE DURATION OF ANY AND ALL IMPLIED WARRANTIES, INCLUDING WARRANTIES OF MERCHANTABILITY AND FITNESS FOR A PARTICULAR PURPOSE TO TWO (2) YEARS ON ALL COMPONENTS FROM THE DATE OF FIRST PURCHASE; AND DESA HEATING PRODUCTS' LIABILITY IS HEREBY LIMITED TO THE PURCHASE PRICE OF THE PRODUCT AND DESA HEATING PRODUCTS SHALL NOT BE LIABLE FOR ANY OTHER DAMAGES WHATSOEVER INCLUDING INDIRECT, INCIDENTAL OR CONSEQUENTIAL DAMAGES.

Some states do not allow a limitation on how long an implied warranty lasts or an exclusion or limitation of incidental or consequential damages, so the above limitation on implied warranties or exclusion or limitation on damages may not apply to you.

This warranty gives you specific legal rights and you may also have other rights that vary from state to state.

For information about this warranty write:



HEATING PRODUCTS

2701 Industrial Drive

P.O. Box 90004

Bowling Green, KY 42102-9004

[www.desatech.com](http://www.desatech.com)



111604 01

NOT A UPC

111604-01

Rev. N

05/06