

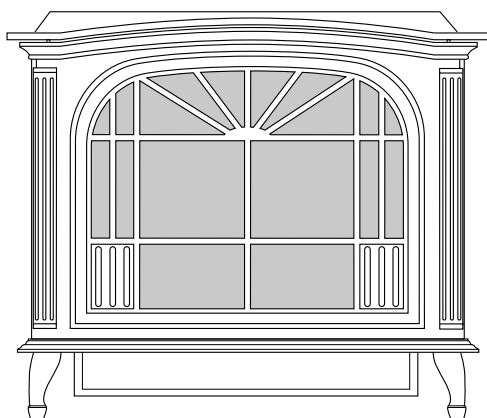

(VENT-FREE) PROPANE/LP GAS STOVE HEATER OWNER'S OPERATION AND INSTALLATION MANUAL



Sun Valley Stove Model MSVFBP Series Variable Manual-Control or Model MSVFBPR Series Remote-Ready Gas Log Heater (Burner System For Cast Iron Stoves)



For technical support call DESA
International's Technical Service
Department at 1-800-DESALOG
(1-800-337-2564).

Patent Pending

WARNING: If the information in this manual is not followed exactly, a fire or explosion may result causing property damage, personal injury, or loss of life.

- Do not store or use gasoline or other flammable vapors and liquids in the vicinity of this or any other appliance.
- **WHAT TO DO IF YOU SMELL GAS**
 - Do not try to light any appliance.
 - Do not touch any electrical switch; do not use any phone in your building.
 - Immediately call your gas supplier from a neighbor's phone. Follow the gas supplier's instructions.
 - If you cannot reach your gas supplier, call the fire department.
- Installation and service must be performed by a qualified installer, service agency, or the gas supplier.

WARNING: The MSVFBP(R) series vent-free gas log heater is only approved for use in the Sun Valley MC(*) series and MCH(P) series cast iron stove models.

(* Indicates Color Suffix Designation)

WARNING: Improper installation, adjustment, alteration, service, or maintenance can cause injury or property damage. Refer to this manual for correct installation and operational procedures. For assistance or additional information consult a qualified installer, service agency, or the gas supplier.

WARNING: This is an unvented gas-fired heater. It uses air (oxygen) from the room in which it is installed. Provisions for adequate combustion and ventilation air must be provided. Refer to *Air for Combustion and Ventilation* section on page 4 of this manual.

This appliance may be installed in an aftermarket*, permanently located, manufactured (mobile) home, where not prohibited by state or local codes.

This appliance is only for use with the type of gas indicated on the rating plate. This appliance is not convertible for use with other gases.

* Aftermarket: Completion of sale, not for purpose of resale, from the manufacturer

Save this manual for future reference.

SUN VALLEY STOVE COMPANY

VENT-FREE PROPANE/LP GAS STOVE HEATER

SAFETY INFORMATION

WARNINGS

IMPORTANT: Read this owner's manual carefully and completely before trying to assemble, operate, or service this heater. Improper use of this heater can cause serious injury or death from burns, fire, explosion, electrical shock, and carbon monoxide poisoning.

 DANGER: Carbon monoxide poisoning may lead to death!

Carbon Monoxide Poisoning: Early signs of carbon monoxide poisoning resemble the flu, with headaches, dizziness, or nausea. If you have these signs, the heater may not be working properly. **Get fresh air at once!** Have heater serviced. Some people are more affected by carbon monoxide than others. These include pregnant women, people with heart or lung disease or anemia, those under the influence of alcohol, and those at high altitudes.

Propane/LP Gas: Propane/LP gas is odorless. An odor-making agent is added to the gas. The odor helps you detect a gas leak. However, the odor added to the gas can fade. Gas may be present even though no odor exists.

Make certain you read and understand all warnings. Keep this manual for reference. It is your guide to safe and proper operation of this heater.

 WARNING: Any change to this heater or its controls can be dangerous.

 WARNING: Do not allow fans to blow directly into the stove. Avoid any drafts that alter burner flame patterns. Ceiling fans can create drafts that alter burner flame patterns. Altered burner patterns can cause sooting.

 WARNING: Do not use a blower insert, heat exchanger insert, or other accessory not approved for use with this heater.

Due to high temperatures, the appliance should be located out of traffic and away from furniture and draperies.

Do not place clothing or other flammable material on or near the appliance. Never place any objects on the heater.

Stove becomes very hot when running heater. Keep children and adults away from hot surfaces to avoid burns or clothing ignition. Stove will remain hot for a time after shutdown. Allow surfaces to cool before touching.

Carefully supervise young children when they are in the room with heater. When using the handheld remote accessory, keep selector switch in the OFF position to prevent children from turning on burners with remote.

Keep the appliance area clear and free from combustible materials, gasoline, and other flammable vapors and liquids.

1. This appliance is only for use with the type of gas indicated on the rating plate. This appliance is not convertible for use with other gases.
2. Do not place propane/LP supply tank(s) inside any structure. Locate propane/LP supply tank(s) outdoors.
3. If you smell gas
 - shut off gas supply
 - do not try to light any appliance
 - do not touch any electrical switch; do not use any phone in your building
 - immediately call your gas supplier from a neighbor's phone. Follow the gas supplier's instructions
 - if you cannot reach your gas supplier, call the fire department
4. This heater shall not be installed in a bedroom or bathroom.
6. Do not use this stove as a wood burning fireplace. Use only model MSVFBP(R) vent-free gas log heater.
6. Do not add extra logs or ornaments such as pine cones, vermiculite, or rock wool. Using these added items can cause sooting.

7. This log heater is designed to be smokeless. If logs ever appear to smoke, turn off heater and call a qualified service person. *Note:* During initial operation, slight smoking could occur due to log curing and heater burning manufacturing residues.
8. To prevent the creation of soot, follow the instructions in *Cleaning and Maintenance*, page 18.
9. Before using furniture polish, wax, carpet cleaners, or similar products, turn heater off. If heated, the vapors from these products may create a white powder residue within burner box or on adjacent walls or furniture.
10. This heater needs fresh, outside air ventilation to run properly. This heater has an Oxygen Depletion Sensing (ODS) safety shutoff system. The ODS shuts down the heater if not enough fresh air is available. See *Air for Combustion and Ventilation*, pages 4 through 6. If heater keeps shutting off, see *Troubleshooting*, pages 19 through 21.
11. Do not run heater
 - where flammable liquids or vapors are used or stored
 - under dusty conditions
12. Do not use this stove to cook food or burn paper or other objects.
13. Do not use heater if any part has been exposed to or under water. Immediately call a qualified service technician to inspect the room heater and to replace any part of the control system and any gas control which has been under water.
14. Do not operate heater if any log is broken. Do not operate heater if a log is chipped (dime-sized or larger).
15. Turn heater off and let cool before servicing. Only a qualified service person should service and repair heater.
16. Operating heater above elevations of 4,500 feet could cause pilot outage.
17. To prevent performance problems, the use of a propane/LP tank of less than 100 lb. capacity is not recommended.
18. Do not place stove directly on carpeting, vinyl tile, or any combustible material other than wood. The stove must set on a metal or wood panel extending the full width and depth of the appliance.

OWNER'S MANUAL

PRODUCT IDENTIFICATION

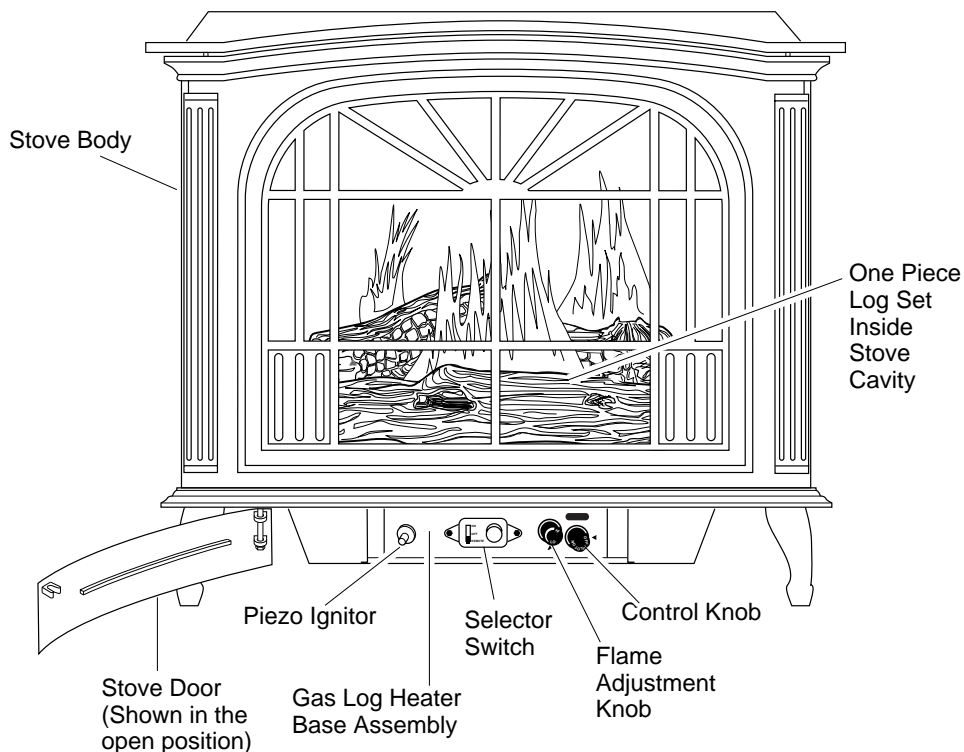

Figure 1 - Typical Stove Cabinet Model (Shown with Model MSVFBPR Heater)

LOCAL CODES

Install and use heater with care. Follow all local codes. In the absence of local codes, use the latest edition of *The National Fuel Gas Code ANS Z223.1*, also known as NFPA 54*.

*Available from:

American National Standards Institute, Inc.
1430 Broadway
New York, NY 10018

National Fire Protection Association, Inc.
Batterymarch Park
Quincy, MA 02269

PRODUCT FEATURES

OPERATION

This heater is clean burning. It requires no outside venting. There is no heat loss out a vent or up a chimney. Heat is generated by realistic, dancing yellow flames. This heater is designed for vent-free operation. State and local codes in some areas prohibit the use of vent-free heaters.

SAFETY PILOT

This heater has a pilot with an Oxygen Depletion Sensing (ODS) safety shutoff system. The ODS/pilot is a required feature for vent-free room heaters. The ODS/pilot shuts off the heater if there is not enough fresh air.

PIEZO IGNITION SYSTEM

This heater has a piezo ignitor. This system requires no matches, batteries, or other sources to light heater.

SUN VALLEY STOVE COMPANY

VENT-FREE PROPANE/LP GAS STOVE HEATER

AIR FOR COMBUSTION AND VENTILATION

⚠ WARNING: This heater shall not be installed in a confined space or unusually tight construction unless provisions are provided for adequate combustion and ventilation air. Read the following instructions to insure proper fresh air for this and other fuel-burning appliances in your home.

Today's homes are built more energy efficient than ever. New materials, increased insulation, and new construction methods help reduce heat loss in homes. Home owners weather strip and caulk around windows and doors to keep the cold air out and the warm air in. During heating months, home owners want their homes as airtight as possible.

While it is good to make your home energy efficient, your home needs to breathe. Fresh air must enter your home. All fuel-burning appliances need fresh air for proper combustion and ventilation.

Exhaust fans, fireplaces, clothes dryers, and fuel burning appliances draw air from the house to operate. You must provide adequate fresh air for these appliances. This will insure proper venting of vented fuel-burning appliances.

PROVIDING ADEQUATE VENTILATION

The following are excerpts from *National Fuel Gas Code, NFPA 54/ANS Z223.1, Section 5.3, Air for Combustion and Ventilation*.

All spaces in homes fall into one of the three following ventilation classifications:

1. Unusually Tight Construction
2. Unconfined Space
3. Confined Space

The information on pages 4 through 6 will help you classify your space and provide adequate ventilation.

Unusually Tight Construction

The air that leaks around doors and windows may provide enough fresh air for combustion and ventilation. However, in buildings of unusually tight construction, you must provide additional fresh air.

Unusually tight construction is defined as construction where:

- a. walls and ceilings exposed to the outside atmosphere have a continuous water vapor retarder with a rating of one perm (6×10^{-11} kg per pa-sec- m^2) or less with openings gasketed or sealed **and**
- b. weather stripping has been added on openable windows and doors **and**
- c. caulking or sealants are applied to areas such as joints around window and door frames, between sole plates and floors, between wall-ceiling joints, between wall panels, at penetrations for plumbing, electrical, and gas lines, and at other openings.

If your home meets all of the three criteria above, you must provide additional fresh air. See *Ventilation Air From Outdoors*, page 6.

If your home does not meet all of the three criteria above, proceed to *Determining Fresh-Air Flow For Heater Location*, page 5.

Confined and Unconfined Space

The National Fuel Gas Code, ANS Z223.1 defines a confined space as a space whose volume is less than 50 cubic feet per 1,000 Btu per hour (4.8 m³ per kw) of the aggregate input rating of all appliances installed in that space and an unconfined space as a space whose volume is not less than 50 cubic feet per 1,000 Btu per hour (4.8 m³ per kw) of the aggregate input rating of all appliances installed in that space. Rooms communicating directly with the space in which the appliances are installed*, through openings not furnished with doors, are considered a part of the unconfined space.

This heater shall not be installed in a confined space or unusually tight construction unless provisions are provided for adequate combustion and ventilation air.

* Adjoining rooms are communicating only if there are doorless passageways or ventilation grills between them.

AIR FOR COMBUSTION AND VENTILATION

Continued

DETERMINING FRESH-AIR FLOW FOR HEATER LOCATION

Determining if You Have a Confined or Unconfined Space

Use this work sheet to determine if you have a confined or unconfined space.

Space: Includes the room in which you will install heater plus any adjoining rooms with doorless passageways or ventilation grills between the rooms.

1. Determine the volume of the space (length x width x height).

Length x Width x Height = _____ cu. ft. (volume of space)

Example: Space size 20 ft. (length) x 16 ft. (width) x 8 ft. (ceiling height) = 2560 cu. ft. (volume of space)

If additional ventilation to adjoining room is supplied with grills or openings, add the volume of these rooms to the total volume of the space.

2. Divide the space volume by 50 cubic feet to determine the maximum Btu/Hr the space can support.

_____ (volume of space) ÷ 50 cu. ft. = (maximum Btu/Hr the space can support)

Example: 2560 cu. ft. (volume of space) ÷ 50 cu. ft. = 51.2 or 51,200 (maximum Btu/Hr the space can support)

3. Add the Btu/Hr of all fuel burning appliances in the space.

Vent-free heater _____ Btu/Hr

Gas water heater* _____ Btu/Hr

Gas furnace _____ Btu/Hr

Vented gas heater _____ Btu/Hr

Gas fireplace logs _____ Btu/Hr

Other gas appliances* + _____ Btu/Hr

Total = _____ Btu/Hr

Example:

Gas water heater 40,000 Btu/Hr

Vent-free heater + 30,000 Btu/Hr

Total = 70,000 Btu/Hr

* Do not include direct-vent gas appliances. Direct-vent draws combustion air from the outdoors and vents to the outdoors.

4. Compare the maximum Btu/Hr the space can support with the actual amount of Btu/Hr used.

_____ Btu/Hr (maximum the space can support)

_____ Btu/Hr (actual amount of Btu/Hr used)

Example: 51,200 Btu/Hr (maximum the space can support)

70,000 Btu/Hr (actual amount of Btu/Hr used)

The space in the above example is a confined space because the actual Btu/Hr used is more than the maximum Btu/Hr the space can support. You must provide additional fresh air. Your options are as follows:

- A. Rework worksheet, adding the space of an adjoining room. If the extra space provides an unconfined space, remove door to adjoining room or add ventilation grills between rooms. See *Ventilation Air From Inside Building*, page 6.
- B. Vent room directly to the outdoors. See *Ventilation Air From Outdoors*, page 6.
- C. Install a lower Btu/Hr heater, if lower Btu/Hr size makes room unconfined.

If the actual Btu/Hr used is less than the maximum Btu/Hr the space can support, the space is an unconfined space. You will need no additional fresh air ventilation.

⚠ WARNING: If the area in which the heater may be operated is smaller than that defined as an unconfined space or if the building is of unusually tight construction, provide adequate combustion and ventilation air by one of the methods described in the *National Fuel Gas Code, ANS Z223.1, Section 5.3* or applicable local codes.

Continued

SUN VALLEY STOVE COMPANY VENT-FREE PROPANE/LP GAS STOVE HEATER

AIR FOR COMBUSTION AND VENTILATION

Continued

VENTILATION AIR

Ventilation Air From Inside Building

This fresh air would come from an adjoining unconfined space. When ventilating to an adjoining unconfined space, you must provide two permanent openings: one within 12" of the ceiling and one within 12" of the floor on the wall connecting the two spaces (see options 1 and 2, Figure 2). You can also remove door into adjoining room (see option 3, Figure 2). Follow the *National Fuel Gas Code, NFPA 54/ANS Z223.1, Section 5.3, Air for Combustion and Ventilation* for required size of ventilation grills or ducts.

⚠ WARNING: Rework worksheet, adding the space of the adjoining unconfined space. The combined spaces must have enough fresh air to supply all appliances in both spaces.

Ventilation Air From Outdoors

Provide extra fresh air by using ventilation grills or ducts. You must provide two permanent openings: one within 12" of the ceiling and one within 12" of the floor. Connect these items directly to the outdoors or spaces open to the outdoors. These spaces include attics and crawl spaces. Follow the *National Fuel Gas Code, NFPA 54/ANS Z223.1, Section 5.3, Air for Combustion and Ventilation* for required size of ventilation grills or ducts.

IMPORTANT: Do not provide openings for inlet or outlet air into attic if attic has a thermostat-controlled power vent. Heated air entering the attic will activate the power vent.

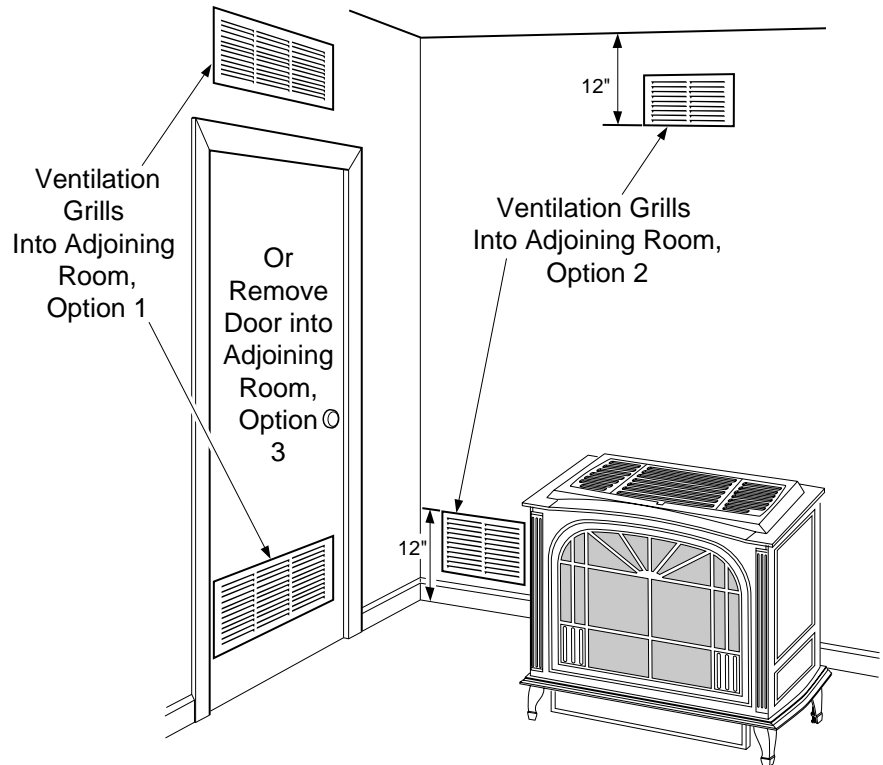

Figure 2 - Ventilation Air from Inside Building

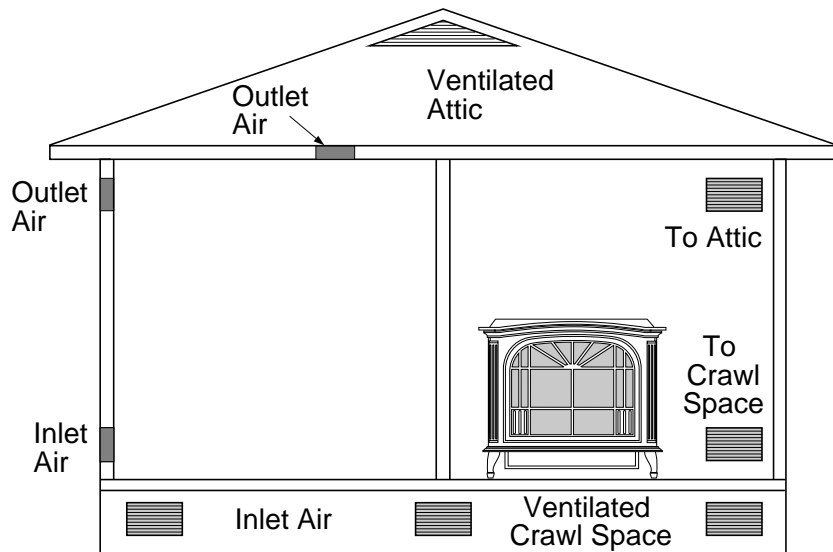

Figure 3 - Ventilation Air from Outdoors

INSTALLATION

NOTICE: This heater is intended for use as supplemental heat. Use this heater along with your primary heating system. Do not install this heater as your primary heat source. If you have a central heating system, you may run system's circulating blower while using heater. This will help circulate the heat throughout the house. In the event of a power outage, you can use this heater as your primary heat source.

WARNING: A qualified service person must install heater. Follow all local codes.

WARNING: Never install the heater

- in a bedroom or bathroom
- in a recreational vehicle
- where curtains, furniture, clothing, or other flammable objects are less than 42 inches from the front, top, or sides of the heater
- in high traffic areas
- in windy or drafty areas

CAUTION: This heater creates warm air currents. These currents move heat to wall surfaces next to heater. Installing heater next to vinyl or cloth wall coverings or operating heater where impurities (such as tobacco smoke, aromatic candles, cleaning fluids, oil or kerosene lamps, etc.) in the air exist, may discolor walls.

IMPORTANT: Vent-free heaters add moisture to the air. Although this is beneficial, installing heater in rooms without enough ventilation air may cause mildew to form from too much moisture. See *Air for Combustion and Ventilation*, pages 4 through 6.

CHECK GAS TYPE

Use only propane/LP gas. If your gas supply is not propane/LP gas, do not install heater. Call dealer where you bought heater for proper type heater.

CLEARANCES TO COMBUSTIBLES (Vent-Free Operation Only)

WARNING: Maintain the minimum clearances. If you can, provide greater clearances from floor, ceiling, and adjoining side and back walls.

Carefully follow the instructions below. This stove is a freestanding unit designed to set directly on the floor. Do not place stove directly on carpeting, vinyl tile, or any combustible material other than wood. The stove must set on a metal or wood panel extending the full width and depth of the appliance.

IMPORTANT: You must maintain minimum wall and ceiling clearances during installation. The minimum clearances are shown in Figure 4. Measure from outermost point of stove top.

Minimum Wall and Ceiling Clearances (see Figure 4)

- Clearances from outermost point of stove top to any combustible side wall should not be less than 12 inches.
- Clearances from outermost point of stove top to any combustible back wall should not be less than 6 inches (Includes Corner Installations).
- Clearances from the stove top to the ceiling should not be less than 48 inches.

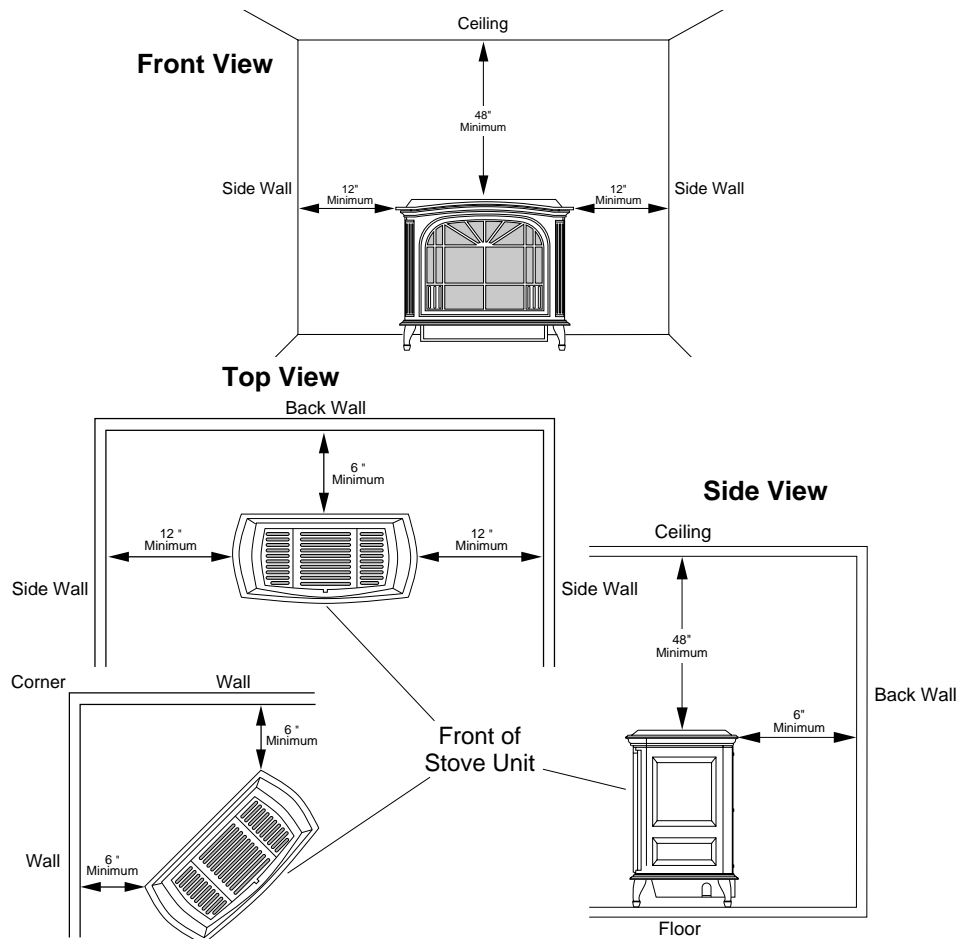

Figure 4 - Minimum Clearance to Walls and Ceiling (Stove May Vary Depending on Model)

Continued

SUN VALLEY STOVE COMPANY

VENT-FREE PROPANE/LP GAS STOVE HEATER

INSTALLATION

Continued

STOVE CAVITY ASSEMBLY

1. Lift off corrugated box enclosing stove body crating.
2. Remove all screws fastening the wood frame enclosure. Spread wood frame open and lift away from plastic-bagged stove body. The bottom pieces of pallet wood will remain bolted to the stove body.
3. Remove plastic bag from stove body.
4. Remove back panel from stove (see Figure 5). Use an adjustable wrench or a 10 mm socket. Remove six (6) bolts and washers. Keep bolts and washers to reattach back panel later.
5. Remove all contents from inside stove cavity. Contents include:
 - (1) - Stove bottom
 - (4) - Legs (include leg leveler bolts)
 - (1) - Bottom door
 - (1) - Top grate
 - (1) - Hardware kit bag with fasteners
6. Carefully lay stove body on back to attach bottom components to stove body (see Figure 6). Rest stove on drop cloth or blanket to avoid scratching stove edges.
7. Remove remaining pallet wood attached to bottom of stove body (see Figure 7). Use an adjustable wrench to remove bolts.

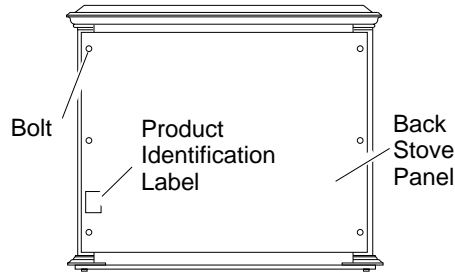

Figure 5 - Removing Back Panel

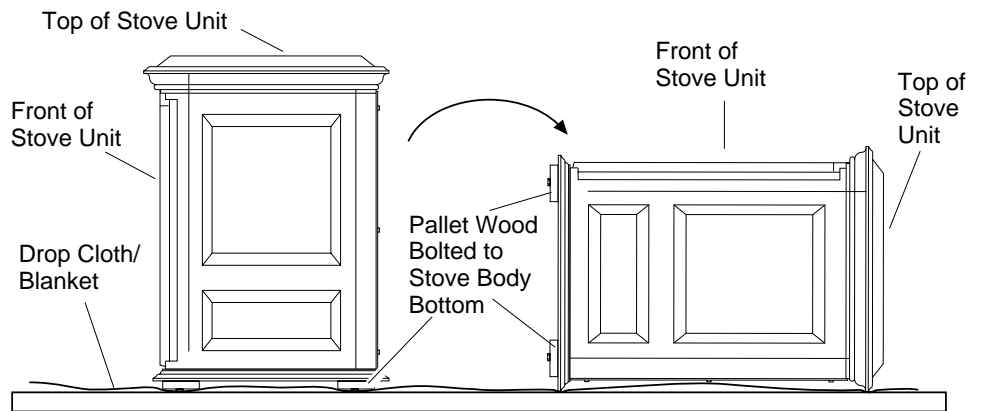

Figure 6 - Laying Down Stove On Side

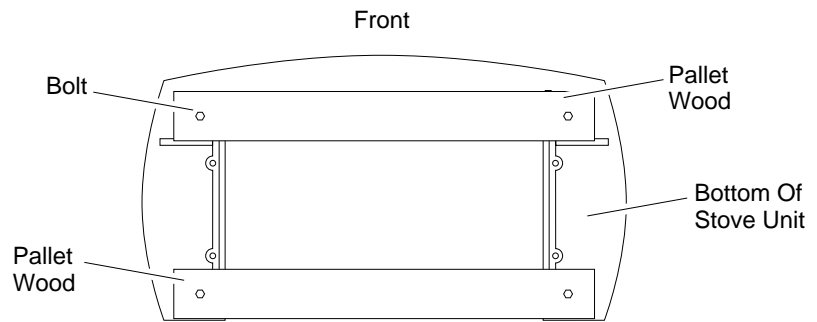

Figure 7 - Removing Pallet Wood From The Bottom of The Stove

⚠ CAUTION: Cast iron is brittle. Do not overtighten bolts or screws during assembly.

8. Fasten each leg to stove with four (4) M8 x 1.25 - 20mm bolts. Use a flat washer and lock washer with each bolt. Tighten bolts into threaded holes on stove body (see Figure 8, this page, and Figure 9 on page 9). Use an adjustable wrench or a 12mm socket.
9. Fasten stove bottom to stove with four (4) M6 x 1 - 25mm bolts. Use a flat washer and lock washer with each bolt. Tighten bolts into threaded holes on stove body (see Figure 8, this page and Figure 10 on page 9). Use an adjustable wrench or a 10mm socket.

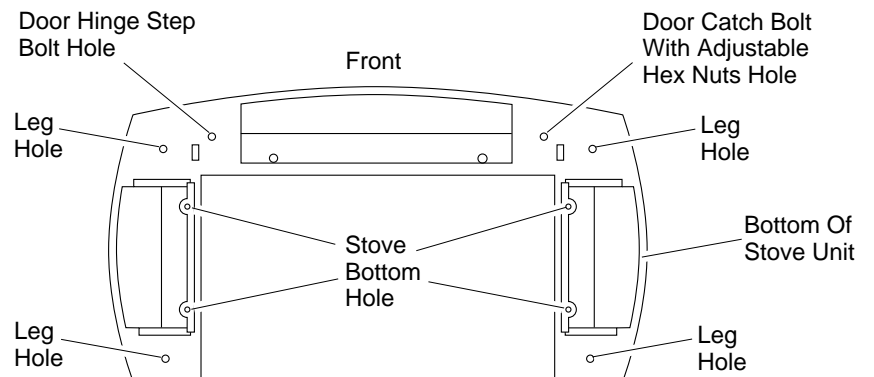

Figure 8 - Locating Threaded Holes for Stove Bottom, Legs, and Door Attachment (Appearance May Vary Depending on Model)

INSTALLATION

Continued

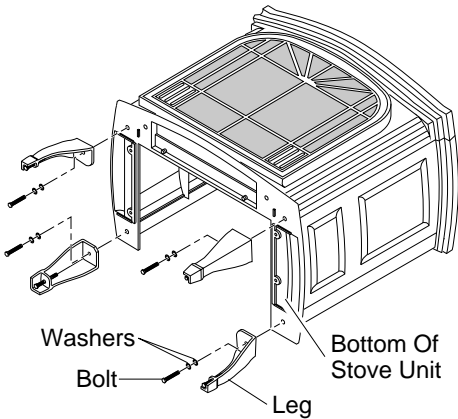

Figure 9 - Attaching Stove Legs

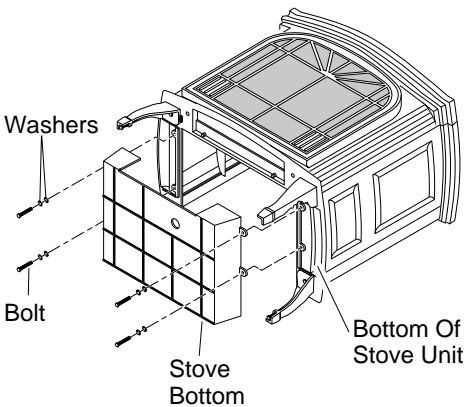

Figure 10 - Attaching Stove Bottom

10. Attach stove door by inserting step bolt through door hinge pivot hole and into threaded hole in stove body (see Figure 8 on page 8 and Figure 11). Use an adjustable wrench or a 12mm socket to fasten step bolt. Tighten step bolt until snug. Make sure door moves freely.
11. Install door catch bolt (M8 x 1.25-55mm with two M8 hex nuts) into threaded hole on stove body (see Figure 8, page 8). Use an adjustable wrench or a 12mm socket. The catch bolt has two hex nuts attached to it (see Figure 12). The top nut is a bolt stop and the bottom nut is for door leveling adjustment.
12. Check general catch bolt alignment with door claw. Make final adjustment and door leveling after stove is in normal standing position.
13. Carefully lift stove back up on its four attached legs.
14. Set top grate into stove top.
15. If available, install gas log heater inside stove cavity before installing the back panel (see *Installing Gas Log Heater Into Stove*, page 10).
16. Fasten back panel to stove with six (6) M6 x 1 - 20mm bolts and washers. Make sure product identification label is located on the outside in lower left-hand corner.

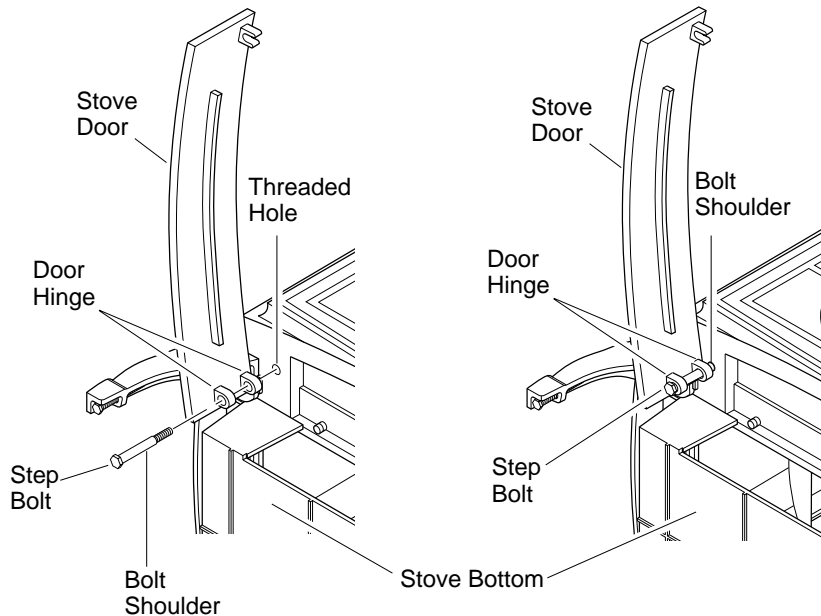

Figure 11 - Attaching Stove Door

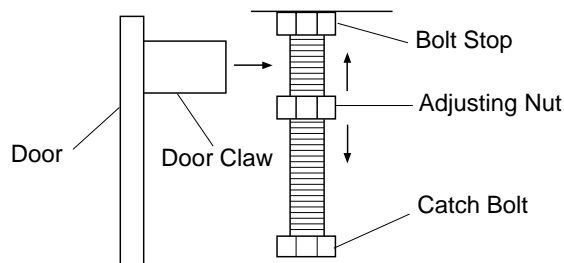

Figure 12 - Catch Bolt and Door Claw Orientation

Continued

SUN VALLEY STOVE COMPANY

VENT-FREE PROPANE/LP GAS STOVE HEATER

INSTALLATION

Continued

INSTALLING GAS LOG HEATER INTO STOVE

CAUTION: Do not remove the metal data plates attached to the heater base assembly. The data plates contain important warranty information.

WARNING: Failure to position the parts in accordance with these diagrams or failure to use only parts specifically approved with this heater may result in property damage or personal injury.

CAUTION: After installation and periodically thereafter, check to ensure that no flame comes in contact with any log. With the heater set to High, check to see if flames contact any log. If so, reposition logs according to the log installation instructions in this manual. Flames contacting logs will create soot.

1. Remove log and gas log heater from carton. *Note:* Do not pick up gas log heater by the burner itself. This could damage heater. Always handle the gas log heater by the heater base only.
2. Remove all protective packaging applied to log and gas log heater for shipment.
3. Check all items for any shipping damage. If damaged, promptly inform dealer where you bought heater.
4. If not already removed, remove back panel from assembled stove body (see Figure 5, page 8). Use an adjustable wrench or a 10 mm socket. Remove six (6) bolts and washers. Keep bolts and washers to reattach back panel later.
5. Set gas log heater inside stove. Make sure control knob extension passes through bottom front opening (see Figure 13).
6. Align outside holes on heater base with four (4) mounting holes on the stove bottom (see Figure 13).

7. Fasten heater base to stove bottom with #10-24 x .50 bolts and hex nuts provided with gas log heater (see Figure 14). Attachment hardware is factory packed inside plastic bag with installation manual and owner's registration card. Push bolt through heater base mounting hole and through stove bottom. Connect hex nut to bolt on underside of stove bottom. The bolt hex head is for a 5/16" socket and the hex nuts are for a 3/8" socket. If sockets are not available, use adjustable wrenches.
8. Set one-piece log on heater base as shown in Figure 15. Make sure middle section at bottom of log is seated into "U" shaped cutout in center of heater base. Log will fit securely on base. **IMPORTANT:** Make sure log does not cover any burner ports and does not touch the stove cavity (see Figure 16).
9. Fasten back panel to stove with six (6) M6 x 1.20mm bolts and washers. Make sure product identification label is located on the outside lower left-hand corner. *Note:* Do not overtighten bolts. Porcelain on back panel may crack.
10. Place freestanding stove in desired position in room. Be sure to maintain clearances to combustibles as outlined on page 7.

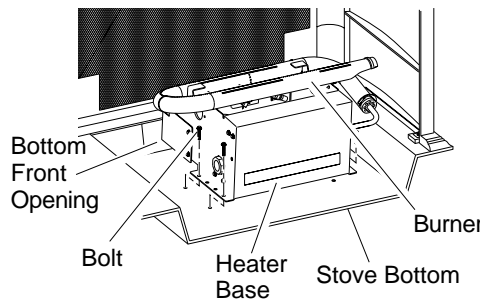

Figure 13 - Placing Heater Base In Stove Cavity (Appearance May Vary Depending on Model)

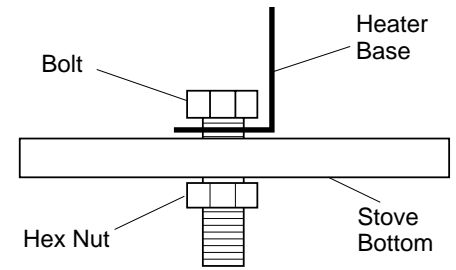

Figure 14 - Fastening Heater Base to Stove Drop Bottom

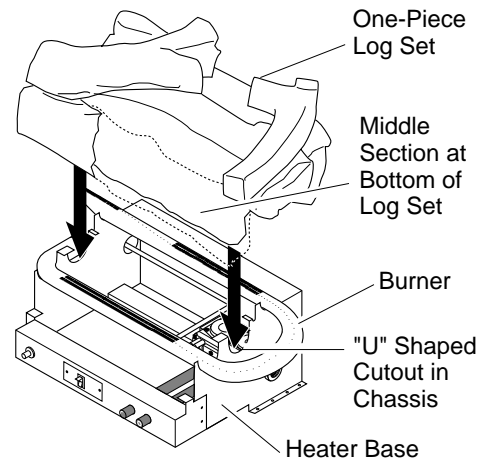

Figure 15 - Installing One-Piece Stove Log Set (Remote-Ready Log Heater Shown)

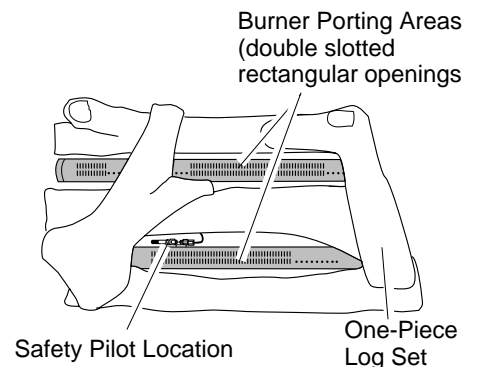

Figure 16 - Top View of One-Piece Log Set on Gas Log Heater

OWNER'S MANUAL

INSTALLATION

Continued

CONNECTING TO GAS SUPPLY

⚠ WARNING: This appliance requires a 1/2" NPT (National Pipe Thread) inlet connection to the pressure regulator.

⚠ WARNING: A qualified service person must connect heater to gas supply. Follow all local codes.

⚠ CAUTION: Never connect heater directly to the propane/LP supply. This heater requires an external regulator (not supplied). Install the external regulator between the heater and propane/LP supply.

Installation Items Needed

Before installing heater, make sure you have the items listed below.

- piping (check local codes)
- sealant (resistant to propane/LP gas)
- equipment shutoff valve *
- test gauge connection *
- sediment trap
- tee joint
- pipe wrench

* An CSA/AGA design-certified equipment shutoff valve with 1/8" NPT tap is an acceptable alternative to test gauge connection. Purchase the optional CSA/AGA design-certified equipment shutoff valve from your dealer. See *Accessories*, page 23.

The gas inlet connection for the stove heater is located on the lower right-hand side of the stove when viewed from the front of the unit. The gas connection can be made either through the bottom right side or through the lower back opening as illustrated in Figure 17. Make sure gas log heater is secured to the stove cavity assembly.

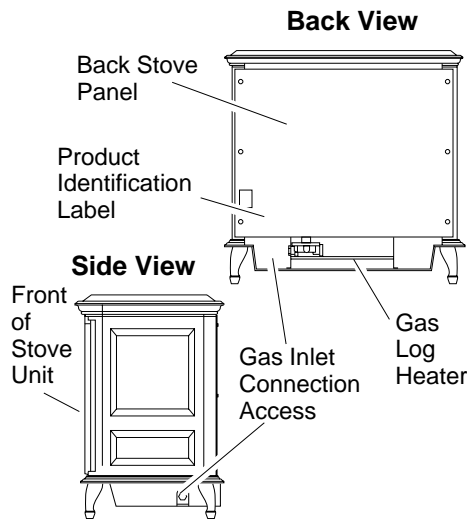

Figure 17 - Gas Regulator Location and Gas Line Access Into Stove Cabinet

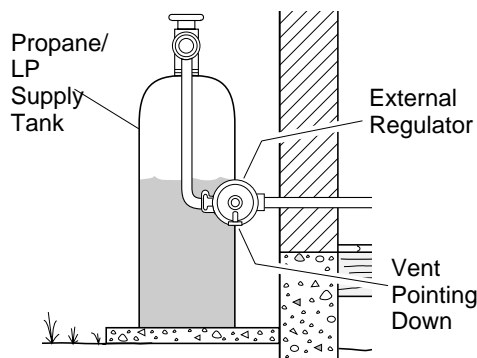

Figure 18 - External Regulator With Vent Pointing Down

The installer must supply an external regulator. The external regulator will reduce incoming gas pressure. You must reduce incoming gas pressure to between 11 and 14 inches of water. If you do not reduce incoming gas pressure, heater regulator damage could occur. Install external regulator with the vent pointing down as shown in Figure 18. Pointing the vent down protects it from freezing rain or sleet.

⚠ WARNING: Never connect heater to private (non-utility) gas wells. This gas is commonly known as wellhead gas.

⚠ CAUTION: Use only new, black iron or steel pipe. Internally-tinned copper tubing may be used in certain areas. Check your local codes. Use pipe of 1/2" diameter or greater to allow proper gas volume to heater. If pipe is too small, undue loss of pressure will occur.

Installation must include an equipment shutoff valve, union, and plugged 1/8" NPT tap. Locate NPT tap within reach for test gauge hook up. NPT tap must be upstream from heater (see Figure 19, MSVFBPR series, or Figure 20, page 12, MSVFBP series).

IMPORTANT: Install equipment shutoff valve in an accessible location. The equipment shutoff valve is for turning on or shutting off the gas to the appliance.

Apply pipe joint sealant lightly to male threads. This will prevent excess sealant from going into pipe. Excess sealant in pipe could result in clogged heater valves.

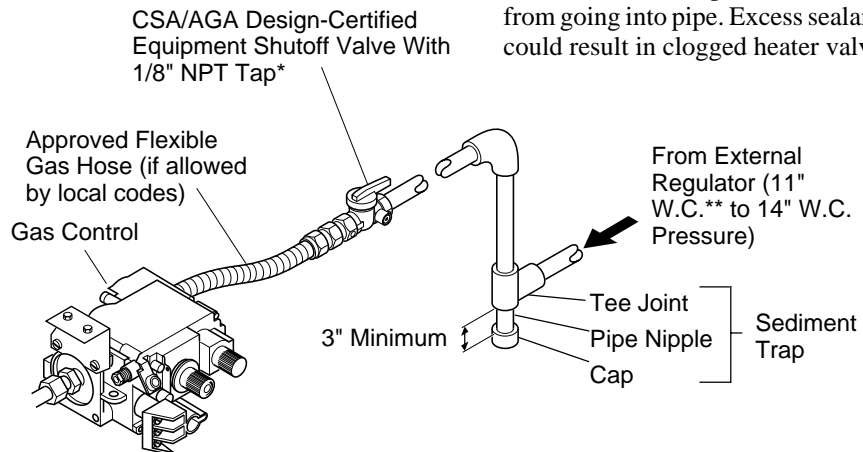

Figure 19 - Gas Connection (MSVFBPR Series)

Continued

SUN VALLEY STOVE COMPANY VENT-FREE PROPANE/LP GAS STOVE HEATER

INSTALLATION

Continued

CAUTION: Use pipe joint sealant that is resistant to liquid petroleum (LP) gas.

Install sediment trap in supply line as shown in Figure 19, page 11 and Figure 20. Locate sediment trap where it is within reach for cleaning. Locate sediment trap where trapped matter is not likely to freeze. A sediment trap traps moisture and contaminants. This keeps them from going into heater controls. If sediment trap is not installed or is installed wrong, heater may not run properly.

CAUTION: Avoid damage to regulator. Hold gas regulator with wrench when connecting it to gas piping and/or fittings.

CHECKING GAS CONNECTIONS

WARNING: Test all gas piping and connections for leaks after installing or servicing. Correct all leaks at once.

WARNING: Never use an open flame to check for a leak. Apply a mixture of liquid soap and water to all joints. Bubbles forming show a leak. Correct all leaks at once.

CAUTION: Make sure external regulator has been installed between propane/LP supply and heater. See guidelines under *Connecting to Gas Supply*, page 11.

Pressure Testing Gas Supply Piping System

Test Pressures In Excess Of 1/2 PSIG (3.5 kPa)

1. Disconnect appliance with its appliance main gas valve (control valve) and equipment shutoff valve from gas supply piping system. Pressures in excess of 1/2 psig will damage heater regulator.
2. Cap off open end of gas pipe where equipment shutoff valve was connected.
3. Pressurize supply piping system by either using compressed air or opening propane/LP supply tank valve.
4. Check all joints of gas supply piping system. Apply mixture of liquid soap and water to gas joints. Bubbles forming show a leak.
5. Correct all leaks at once.
6. Reconnect heater and equipment shutoff valve to gas supply. Check reconnected fittings for leaks.

Test Pressures Equal To or Less Than 1/2 PSIG (3.5 kPa)

1. Close equipment shutoff valve (see Figure 21).
2. Pressurize supply piping system by either using compressed air or opening propane/LP supply tank valve.
3. Check all joints from gas meter to equipment shutoff valve (see Figure 22). Apply mixture of liquid soap and water to gas joints. Bubbles forming show a leak.
4. Correct all leaks at once.

Pressure Testing Heater Gas Connections

1. Open equipment shutoff valve (see Figure 21).
2. Open propane/LP supply tank valve.
3. Make sure control knob of heater is in the OFF position.
4. Check all joints from equipment shutoff valve to control valve (see Figure 22). Apply mixture of liquid soap and water to gas joints. Bubbles forming show a leak.
5. Correct all leaks at once.
6. Light heater (see *Operating Heater*, pages 14 through 17). Check all other internal joints for leaks.
7. Turn off heater (see *To Turn Off Gas to Appliance*, remote-ready models, page 15, variable manual models, page 16).

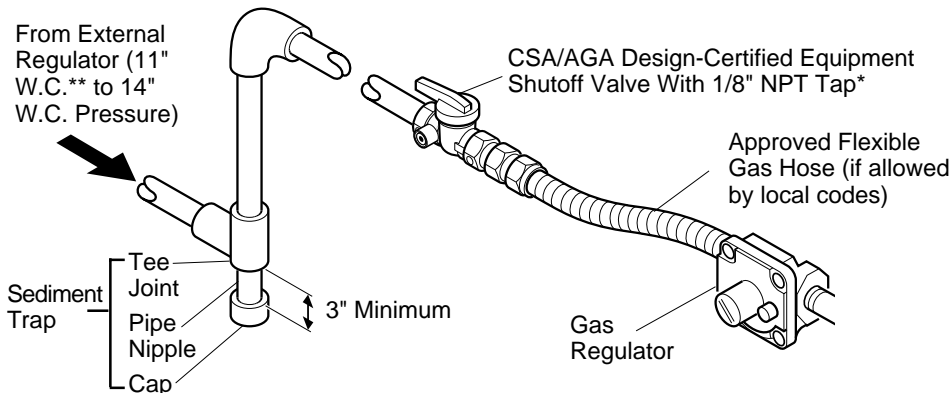

Figure 20 - Gas Connection (MSVFBP Series)

* Purchase the optional CSA/AGA design-certified equipment shutoff valve from your dealer. See *Accessories*, page 23.

** Minimum inlet pressure for purpose of input adjustment.

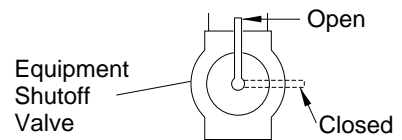

Figure 21 - Equipment Shutoff Valve

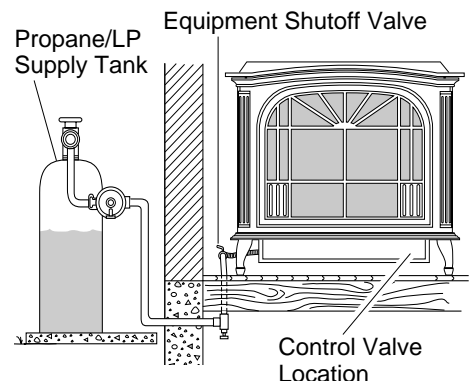

Figure 22 - Checking Gas Joints

INSTALLATION

Continued

INSTALLING OPTIONAL WALL MOUNTED THERMOSTAT - GWMT1

⚠ WARNING: Installation must be done by a qualified installer familiar with low voltage wiring procedures.

⚠ WARNING: Do not connect this thermostat to any electrical source! Electrical shock and/or fire hazard will occur.

1. Unscrew back panel on the stove and remove the log set from heater base. This will give you access to the valve.
2. Disconnect from the valve the wires running from the ON/OFF switch.
3. Run the wires from the wall thermostat through the rectangular cut-out in the back of the heater base. Connect one terminal of the wire for the wall thermostat to the THTP terminal on the valve. Connect remaining wire terminal to the TH terminal on the valve. Make sure that the wire terminals are in the positions on the unit as pictured in Figure 23. If wires are not connected as shown the thermostat will not work.
4. Route the wire to a convenient location to mount your thermostat (no outside wall). **IMPORTANT:** The wire must not exceed 25 feet in length.

The thermostat should be mounted 54" above the floor in a location where there is good air circulation. Avoid heat sources such as lamps, direct sunlight, fireplace, or heat and air conditioning ducts.

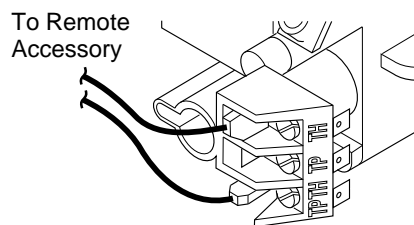

Figure 23- Control Valve Terminals

5. Gently remove the cover of the thermostat from the base. Grasp the sides of the cover firmly and pull to separate from the base.
6. Feed the electrical wires through the rectangular slots (from the back) on each side of the base (see Figure 24).

⚠ WARNING: Do not connect this thermostat to a power source. Electrical shock and/or fire hazard will occur.

7. Connect one bare wire end to each terminal ("W" and "R") of the thermostat base (see Figure 25).
8. Install the base to the wall with screws provided with thermostat.
9. Move the temperature adjustment back and forth to insure the bi-metal is free from restrictions.
10. Replace the cover onto the base. (Upon installation, the thermostat must be allowed to stabilize at room temperature for a minimum of 30 minutes for proper operation.)
11. Set the temperature adjustment to the desired setting. This thermostat has been electronically calibrated at the factory. No adjustment or leveling is necessary.

Feed wires through rectangular slots

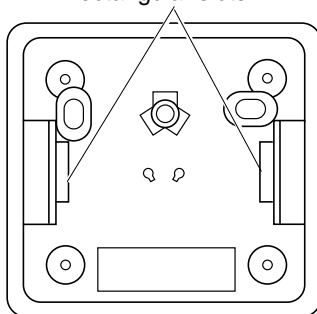

Figure 24- Back View of Thermostat Base

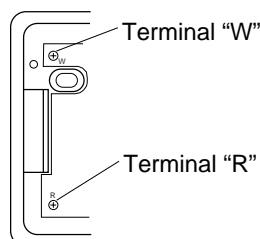

Figure 25 - Thermostat Base Terminal "W" and "R"

INSTALLING OPTIONAL WIRELESS HAND-HELD REMOTE CONTROL

Follow all installation instructions included with the GHRC Series and GHRCT Series wireless hand-held remote control kits (see *Accessories*, page 23).

SUN VALLEY STOVE COMPANY

VENT-FREE PROPANE/LP GAS STOVE HEATER

OPERATING HEATER

FOR YOUR SAFETY READ BEFORE LIGHTING

⚠ WARNING: If you do not follow these instructions exactly, a fire or explosion may result causing property damage, personal injury or loss of life.

- A. This appliance has a pilot which must be lighted by hand. When lighting the pilot, follow these instructions exactly.
- B. **BEFORE LIGHTING** smell all around the appliance area for gas. Be sure to smell next to the floor because some gas is heavier than air and will settle on the floor.

WHAT TO DO IF YOU SMELL GAS

- Do not try to light any appliance.
 - Do not touch any electric switch; do not use any phone in your building.
 - Immediately call your gas supplier from a neighbor's phone. Follow the gas supplier's instructions.
 - If you cannot reach your gas supplier, call the fire department.
- C. Use only your hand to push in or turn the gas control knob. Never use tools. If the knob will not push in or turn by hand, don't try to repair it, call a qualified service technician or gas supplier. Force or attempted repair may result in a fire or explosion.
 - D. Do not use this appliance if any part has been under water. Immediately call a qualified service technician to inspect the appliance and to replace any part of the control system and any gas control which has been under water.

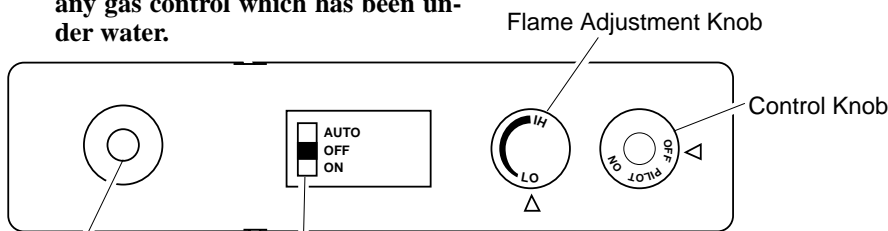

Ignitor Button Selector Switch in OFF Position

Figure 26 - Control Knob and Ignitor Button Location (Shown as Supplied, No Control Options)

LIGHTING INSTRUCTIONS

MSVFBPR REMOTE-READY MODELS

NOTICE: During initial operation of new heater, burning logs will give off a paper-burning smell. Open window to vent smell. This will only last a few hours.

1. STOP! Read the safety information, column 1.
2. Make sure equipment shutoff valve is fully open.
3. Set switch to OFF position.

⚠ WARNING: Burners will come on automatically within one minute when the selector switch is in the ON position after the pilot is lit.

4. Press in and turn control knob clockwise to the OFF position.
5. Wait five (5) minutes to clear out any gas. Then smell for gas, including near the floor. If you smell gas, STOP! Follow "B" in the safety information column 1. If you don't smell gas, go to the next step.
6. Press in and turn control knob counterclockwise to the PILOT position. Press in control knob for five (5) seconds (see Figure 26).

Note: You may be running this heater for the first time after hooking up to gas supply. If so, the control knob may need to be pressed in for 30 seconds or more. This will allow air to bleed from the gas system.

7. With control knob pressed in, press and release ignitor button. This will light pilot. The pilot is attached to the front burner. If needed, keep pressing ignitor button until pilot lights.

Note: If pilot does not stay lit, contact a qualified service person or gas supplier for repairs. Until repairs are made, light pilot with match. To light pilot with match, see *Manual Lighting Procedure* on page 15.

8. Keep control knob pressed in for 30 seconds after lighting pilot. After 30 seconds, release control knob.
 - If control knob does not pop out when released, contact a qualified service person or gas supplier for repairs.

Note: If pilot goes out, repeat steps 4 through 8.
9. Slightly push in and turn control knob counterclockwise to the ON position.
10. Wait one minute and switch selector switch to the ON position to light burners. **Note:** AUTO is only functional when using GWMT1 or GWMS2 optional accessories.
11. Set flame adjustment knob to any level between HI and LO.

⚠ CAUTION: Do not try to adjust heating levels by using the equipment shutoff valve.

⚠ WARNING: Make sure the selector switch is in the OFF position when you are away from home for long periods of time. Heater will come on automatically with selector switch in the ON position.

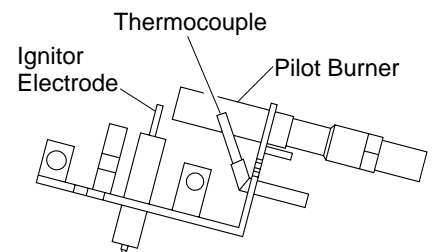



Figure 27 - Pilot

OPERATING HEATER

Continued

TO TURN OFF GAS TO APPLIANCE

Shutting Off Heater

1. Turn control knob clockwise  to the OFF position.
- 2a. Set selector switch in the OFF position.
- 2b. If Using Optional Hand-Held Remote: Set selector switch in the OFF position to keep from draining battery.

Shutting Off Burners Only (pilot stays lit)

You may shut off the burners and keep the pilot lit by doing one of the following:

1. Turn control knob clockwise  to the PILOT position.
2. Use remote control manual OFF button.
3. Set selector switch in the OFF position.

MANUAL LIGHTING PROCEDURE

1. Follow steps 1 through 6 under *Lighting Instructions*, page 14.
2. Depress control knob and light pilot with match.
3. Keep control knob pressed in for 30 seconds after lighting pilot. After 30 seconds, release control knob. Now follow steps 9 through 11, page 14.

OPTIONAL REMOTE OPERATION

Note: All remote control accessories must be purchased separately (see *Accessories*, page 23). Follow instructions included with the remote control.

Thermostat Control Operation

(Optional GHRCT Only) The thermostat control setting on the remote control unit can be set to any comfort level between WARMER and COOLER. The burners will turn on and off automatically to maintain the comfort level you select. The ideal comfort setting will vary by household depending upon the amount of space to be heated, the output of the central heating system, etc.

For wall thermostat operation, follow instruction supplied with thermostat accessory GWMT1. For wall switch operation follow instructions supplied with GWMS2.

NOTICE: You must light the pilot before using the hand-held remote control unit. See *Lighting Instructions* on page 14.

1. After lighting, let pilot flame burn for about one minute. Turn control knob to ON position. Adjust flame adjustment knob anywhere between HI and LO. Slide the selector switch to the REMOTE position. **Note:** The burners may light if hand-held ON button was on when remote selector switch was last turned off. You can now turn the burners on and off with the hand-held remote control unit.

IMPORTANT: Be sure to press the ON/OFF buttons on the hand-held remote control unit for up to 3 seconds to assure proper operation.

IMPORTANT: Do not leave the selector switch in the REMOTE position when the pilot is not lit. This will drain the battery.

GHRC Series Operation:

- 2a. Press the ON/OFF button to turn the burners on and off. When turning burners off, the pilot will remain lit.

GHRCT Series Operation:

- 2b. Press the AUTO/ON/OFF button on the hand-held remote control (see Figure 29). The lights to the left of the button will show AUTO, ON, or OFF.
 - In the ON mode, the burners will ignite. The heater is in manual mode when ON is lit.

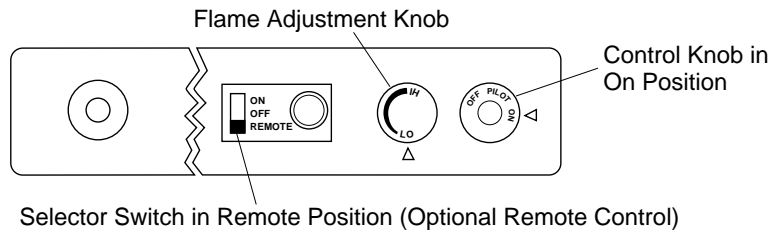

Figure 28 - Setting the Remote Selector Switch, Control Knob, and Flame Adjustment Knob for Remote Operation

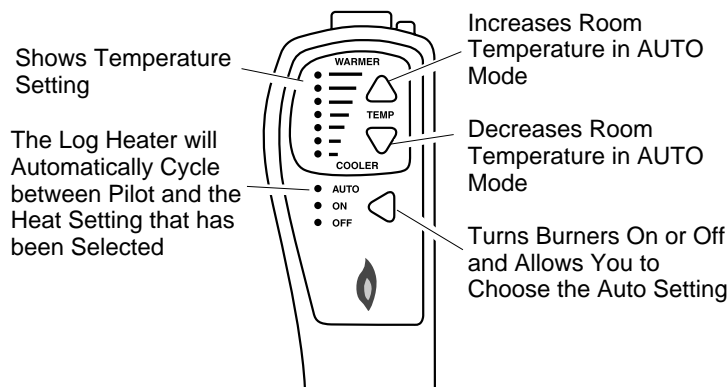

Figure 29 - Thermostat Hand-Held Remote Control Unit Selections (GHRCT Series Only)

SUN VALLEY STOVE COMPANY

VENT-FREE PROPANE/LP GAS STOVE HEATER

OPERATING HEATER

Continued

- In the AUTO mode, the thermostat in the hand-held remote unit controls the room temperature. To increase the room temperature, press the top arrow of the TEMP button. To lower the room temperature, press the bottom arrow of the TEMP button. At higher settings the heater will run longer.

IMPORTANT: This remote control has been specially engineered to take an air temperature sample every minute in the auto mode. It will not respond immediately to the temperature setting being turned up or down.

IMPORTANT: The hand-held remote control unit must be near the heater. Do not keep the hand-held remote control unit too close to the heater. The thermostat on the hand-held remote control unit will heat up too quickly and turn the heater off.

- To turn the burner off, press the AUTO/ON/OFF button until OFF lights. The pilot will remain lit.

IMPORTANT: To turn the pilot off, manually turn the control knob on the heater to the OFF position.

LIGHTING INSTRUCTIONS

MSVFBP VARIABLE MANUAL-CONTROL MODELS

NOTICE: During initial operation of new heater, burning logs will give off a paper-burning smell. Open damper or window to vent smell. This will only last a few hours.

- STOP! Read the safety information page 14, column 1.
- Make sure equipment shutoff valve is fully open.
- Press in and turn control knob clockwise to the OFF position.

- Wait five (5) minutes to clear out any gas. Then smell for gas, including near the floor. If you smell gas, STOP! Follow "B" in the safety information on page 14, column 1. If you don't smell gas, go to the next step.

- Slightly depress and turn control knob counterclockwise to the PILOT position. Keep control knob pressed in for five (5) seconds (see Figure 30).

Note: You may be running this heater for the first time after hooking up to gas supply. If so, the control knob may need to be pressed in for 30 seconds. This will allow air to bleed from the gas system.

- With control knob pressed in, press and release ignitor button. This will light pilot. The pilot is attached to the burner (see Figure 16, page 10). If needed, keep pressing ignitor button until pilot lights.

Note: If pilot does not light, contact a qualified service person or gas supplier for repairs. Until repairs are made, light pilot with match. To light pilot with match, see *Manual Lighting Procedure*.

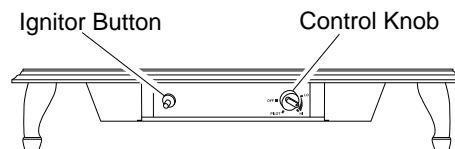

Figure 30 - Control Knob and Ignitor Button Location

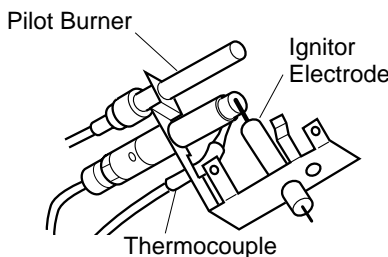

Figure 31 - Pilot

- Keep control knob pressed in for 30 seconds after lighting pilot. After 30 seconds, release control knob.

Note: If pilot goes out, repeat steps 3 through 7.

- If control knob does not pop out when released, contact a qualified service person or gas supplier for repairs.

- Slightly depress and turn control knob counterclockwise to the HIGH position. The burners should light. Set control knob to any heat level between HIGH and LO.

VARIABLE CONTROL OPERATION

The variable control valve can be set to any heat setting and flame height desired, by simply turning the control knob until that setting is attained. Even the lowest setting provides realistic, dancing yellow flames. Selecting higher settings produces greater heat output. This results in increased heating comfort.

WARNING: Do not operate heater between PILOT and HIGH positions.

CAUTION: Do not try to adjust heating levels by using the equipment shutoff valve

TO TURN OFF GAS TO APPLIANCE

Shutting Off Heater

- Press in and turn control knob clockwise to the HIGH position.
- Turn the control knob clockwise to the PILOT position.
- Press in control knob and turn clockwise to the OFF Position.

Shutting Off Burners Only (pilot stays lit)

- Turn the control knob clockwise to the HIGH position.
- Press in and turn control knob clockwise to the PILOT position.

OPERATING HEATER

Continued

MANUAL LIGHTING PROCEDURE

1. Follow steps 1 through 5 under *Lighting Instructions*, page 16.
2. Pilot is located inside stove cavity attached to burner. Lift off top grate to allow access to pilot.
3. Depress control knob and light pilot with match.
4. Keep control knob pressed in for 30 seconds after lighting pilot. After 30 seconds, release control knob.
5. Place top grate back into position. Now follow step 8 under *Lighting Instructions*, page 16.

INSPECTING BURNERS

Check pilot flame pattern and burner flame patterns often.

PILOT FLAME PATTERN (Remote-Ready Models)

Figure 32 shows a correct pilot flame pattern. Figure 33 shows an incorrect pilot flame pattern. The incorrect pilot flame is not heating the thermocouple. This will cause the thermocouple to cool. When the thermocouple cools, the heater will shut down.

If pilot flame pattern is incorrect, as shown in Figure 33

- turn heater off (see *To Turn Off Gas to Appliance*, page 15)
- see *Troubleshooting*, pages 19 through 21

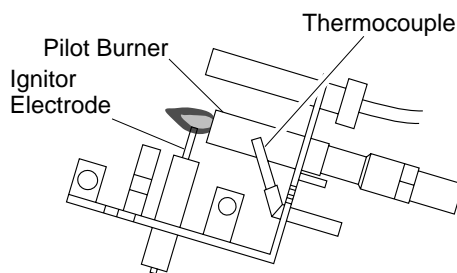

Figure 32 - Correct Pilot Flame Pattern

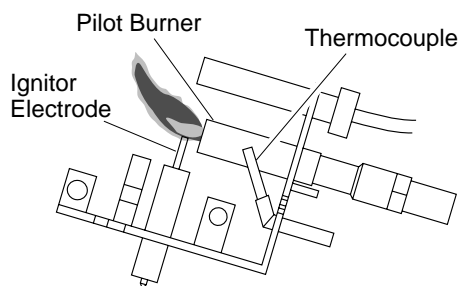

Figure 33 - Incorrect Pilot Flame Pattern

PILOT FLAME PATTERN (Variable Manual-Control Models)

Figure 34 shows a correct pilot flame pattern. Figure 35 shows an incorrect pilot flame pattern. The incorrect pilot flame is not heating the thermocouple. This will cause the thermocouple to cool. When the thermocouple cools, the heater will shut down.

If pilot flame pattern is incorrect, as shown in Figure 35

- turn heater off (see *To Turn Off Gas to Appliance*, page 16)
- see *Troubleshooting*, pages 19 through 21

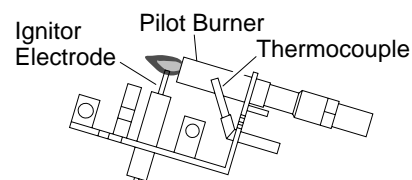

Figure 34 - Correct Pilot Flame Pattern

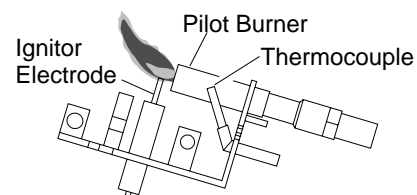

Figure 35 - Incorrect Pilot Flame Pattern

BURNER PRIMARY AIR HOLES

Air is drawn into the burner through the holes in the fitting at the burner entrance. These holes may become blocked with dust or lint. Periodically inspect these holes for any blockage and clean if needed. Blocked air holes will create soot.

MAIN BURNER

Periodically inspect all burner flame holes with the heater running. All slotted burner flame holes should be open with yellow flame present. All round burner flame holes should be open with a small blue flame present. Some burner flame holes may become blocked by debris or rust, with no flame present. If so, turn off heater and let cool. Either remove blockage or replace burner. Blocked burner flame holes will create soot.

SUN VALLEY STOVE COMPANY

VENT-FREE PROPANE/LP GAS STOVE HEATER

CLEANING AND MAINTENANCE

⚠ WARNING: Turn off heater and let cool before cleaning.

⚠ CAUTION: You must keep control areas, burner, and circulating air passageways of heater clean. Inspect these areas of heater before each use. Have heater inspected yearly by a qualified service person. Heater may need more frequent cleaning due to excessive lint from carpeting, pet hair, bedding material, etc.

CLEANING BURNER INJECTOR HOLDER AND PILOT AIR INLET HOLE

The primary air inlet holes allow the proper amount of air to mix with the gas. This provides a clean burning flame. Keep these holes clear of dust, dirt, lint, and pet hair. Clean these air inlet holes prior to each heating season. Blocked air holes will create soot. We recommend that you clean the unit every three months during operation and have heater inspected yearly by a qualified service person.

We also recommend that you keep the burner tube and pilot assembly clean and free of dust and dirt. To clean these parts we recommend using compressed air no greater than 30 PSI. Your local computer store, hardware store, or home center may carry compressed air in a can. You can use a vacuum cleaner in the blow position. If using compressed air in a can, please follow the directions on the can. If you don't follow directions on the can, you could damage the pilot assembly. **Note:** Removing the rear panel (Figure 5, page 8) and top grates of your stove will make cleaning easier.

1. Shut off the unit, including the pilot. Allow the unit to cool for at least thirty minutes.
2. Inspect burner, pilot, and primary air inlet holes on injector holder for dust and dirt (see Figure 36).
3. Blow air through the ports/slots and holes in the burner.

4. Check the injector holder located at the end of the burner tube again. Remove any large particles of dust, dirt, lint, or pet hair with a soft cloth or vacuum cleaner nozzle.
5. Blow air into the primary air holes on the injector holder.
6. In case any large clumps of dust have now been pushed into the burner repeat steps 3 and 4.

Clean the pilot assembly also. A yellow tip on the pilot flame indicates dust and dirt in the pilot assembly. There is a small pilot air inlet hole about two inches from where the pilot flame comes out of the pilot assembly (see Figure 37). With the unit off, lightly blow air through the air inlet hole. You may blow through a drinking straw if compressed air is not available.

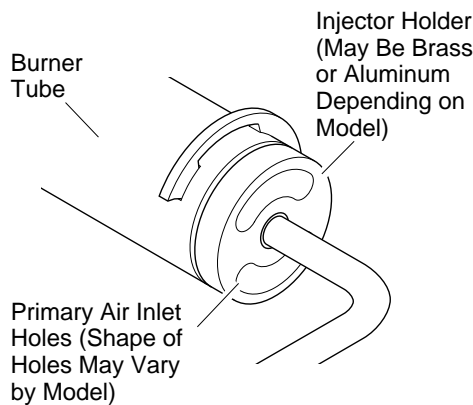

Figure 36 - Injector Holder On Outlet Burner Tube

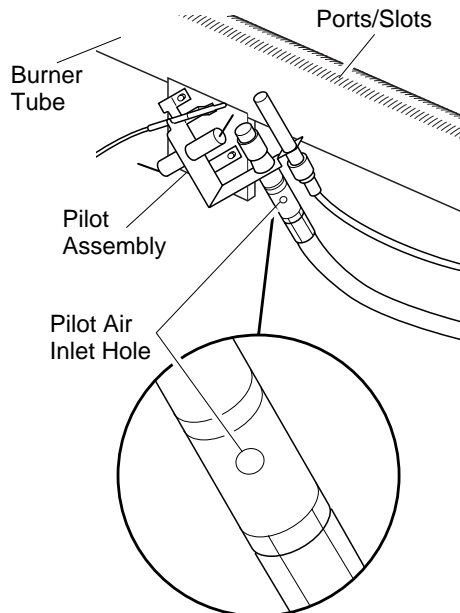

Figure 37 - Pilot Inlet Air Hole

LOGS

- If you remove logs for cleaning, refer to *Installing Gas Log Heater into Stove*, page 10, to properly replace logs.
- Replace log(s) if broken or chipped (dime-sized or larger).

MAIN BURNER

Periodically inspect all burner flame holes with the heater running. All slotted burner flame holes should be open with yellow flame present. All round burner flame holes should be open with a small blue flame present. Some burner flame holes may become blocked by debris or rust, with no flame present. If so, turn off heater and let cool. Either remove blockage or replace burner. Blocked burner flame holes will create soot.

Review your video included with your heater for additional cleaning instructions.

TRANSPORTING STOVE

Porcelain enamel coatings contain glass and are brittle. To prevent cracking of the porcelain finish, do not transport stove with top grates in place.

OWNER'S MANUAL

TROUBLESHOOTING

Note: For additional help, visit DESA International's technical service web site at www.desatech.com.

⚠ WARNING: Turn off heater and let cool before servicing. Only a qualified service person should service and repair heater.

⚠ CAUTION: Never use a wire, needle, or similar object to clean ODS/pilot. This can damage ODS/pilot unit.

Note: All troubleshooting items are listed in order of operation.

OBSERVED PROBLEM	POSSIBLE CAUSE	REMEDY
When ignitor button is pressed, there is no spark at ODS/pilot	<ol style="list-style-type: none"> Ignitor electrode not connected to ignitor cable Ignitor cable pinched or wet Broken ignitor cable Bad piezo ignitor Ignitor electrode broken Ignitor electrode positioned wrong 	<ol style="list-style-type: none"> Reconnect ignitor cable Free ignitor cable if pinched by any metal or tubing. Keep ignitor cable dry Replace ignitor cable Replace piezo ignitor Replace piezo ignitor Replace piezo ignitor
When ignitor button is pressed, there is spark at ODS/pilot but no ignition	<ol style="list-style-type: none"> Gas supply turned off or equipment shutoff valve closed Control knob not in PILOT position Control knob not pressed in while in PILOT position Air in gas lines when installed ODS/pilot is clogged Gas regulator setting is not correct Depleted gas supply 	<ol style="list-style-type: none"> Turn on gas supply or open equipment shutoff valve Turn control knob to PILOT position Press in control knob while in PILOT position Continue holding down control knob. Repeat igniting operation until air is removed Clean ODS/pilot (see <i>Cleaning and Maintenance</i>, page 18) or replace ODS/pilot assembly Replace gas control Contact local propane/LP gas company
ODS/pilot lights but flame goes out when control knob is released	<ol style="list-style-type: none"> Control knob not fully pressed in Control knob not pressed in long enough Equipment shutoff valve not fully open Pilot flame not touching thermocouple, which allows thermocouple to cool, causing pilot flame to go out. This problem could be caused by one or both of the following: <ol style="list-style-type: none"> Low gas pressure Dirty or partially clogged ODS/pilot Thermocouple connection loose at control valve Thermocouple damaged Control valve damaged 	<ol style="list-style-type: none"> Press in control knob fully After ODS/pilot lights, keep control knob pressed in 30 seconds Fully open equipment shutoff valve <ol style="list-style-type: none"> Contact local propane/LP gas company Clean ODS/pilot (see <i>Cleaning and Maintenance</i>, page 18) or replace ODS/pilot assembly Hand tighten until snug, then tighten 1/4 turn more Replace thermocouple Replace control valve
Burner does not light after ODS/pilot is lit	<ol style="list-style-type: none"> Burner orifice clogged Inlet gas pressure is too low Burner orifice diameter is too small Thermopile leads disconnected or improperly connected Burners will not come on in remote position 	<ol style="list-style-type: none"> Clean burner (see <i>Cleaning and Maintenance</i>, page 18) or replace burner orifice Contact local propane/LP gas company Replace burner orifice Reconnect leads (see <i>Wiring Diagram</i>, page 22) Replace battery in transmitter and receiver

SUN VALLEY STOVE COMPANY

VENT-FREE PROPANE/LP GAS STOVE HEATER

TROUBLESHOOTING

Continued

OBSERVED PROBLEM	POSSIBLE CAUSE	REMEDY
Delayed ignition burner	<ol style="list-style-type: none"> 1. Manifold pressure is too low 2. Burner orifice clogged 	<ol style="list-style-type: none"> 1. Contact local propane/LP gas company 2. Clean burner (see <i>Cleaning and Maintenance</i>, page 18) or replace burner orifice
Burner backfiring during combustion	<ol style="list-style-type: none"> 1. Burner orifice is clogged or damaged 2. Damaged burner 3. Gas regulator defective 	<ol style="list-style-type: none"> 1. Clean burner (see <i>Cleaning and Maintenance</i>, page 18) or replace burner orifice 2. Replace damaged burner 3. Replace gas control
Slight smoke or odor during initial operation	<ol style="list-style-type: none"> 1. Not enough air 2. Gas regulator defective 3. Residues from manufacturing processes and logs curing 	<ol style="list-style-type: none"> 1. Check burner for dirt and debris. If found, clean burner (see <i>Cleaning and Maintenance</i>, page 18) 2. Replace gas control 3. Problem will stop after a few hours of operation
Moisture/condensation noticed on windows	<ol style="list-style-type: none"> 1. Not enough combustion/ventilation air 	<ol style="list-style-type: none"> 1. Refer to <i>Air for Combustion and Ventilation</i> requirements (page 4)
Heater produces a whistling noise when burner is lit	<ol style="list-style-type: none"> 1. Turning control knob to HI position when burner is cold 2. Air in gas line 3. Air passageways on heater blocked 4. Dirty or partially clogged burner orifice 	<ol style="list-style-type: none"> 1. Turn control knob to LO position and let warm up for a minute 2. Operate burner until air is removed from line. Have gas line checked by local propane/LP gas company 3. Observe minimum installation clearances (see page 7) 4. Clean burner (see <i>Cleaning and Maintenance</i>, page 18) or replace burner orifice
Dark residue on logs or inside of fireplace	<ol style="list-style-type: none"> 1. Improper log placement 2. Drafts or other air currents affecting flame pattern 3. Air holes at burner inlet blocked 4. Burner flame holes blocked 	<ol style="list-style-type: none"> 1. Properly locate logs (see <i>Installing Gas Log Heater Into Stove</i>, page 10) 2. Eliminate source of drafts around heater 3. Clean out air holes at burner inlet. Periodically repeat as needed 4. Remove blockage or replace burner
White powder residue forming within burner box or on adjacent walls or furniture	<ol style="list-style-type: none"> 1. When heated, vapors from furniture polish, wax, carpet cleaners, etc. turn into white powder residue 	<ol style="list-style-type: none"> 1. Turn heater off when using furniture polish, wax, carpet cleaners, or similar products
Remote does not function	<ol style="list-style-type: none"> 1. Battery is not installed. Battery power is low 	<ol style="list-style-type: none"> 1. Replace 9-volt batteries in receiver and remote control

TROUBLESHOOTING

Continued

- ⚠ WARNING: If you smell gas**
- **Shut off gas supply.**
 - **Do not try to light any appliance.**
 - **Do not touch any electrical switch; do not use any phone in your building.**
 - **Immediately call your gas supplier from a neighbor's phone. Follow the gas supplier's instructions.**
 - **If you cannot reach your gas supplier, call the fire department.**

IMPORTANT: Operating heater where impurities in air exist may create odors. Cleaning supplies, paint, paint remover, cigarette smoke, cements and glues, new carpet or textiles, etc., create fumes. These fumes may mix with combustion air and create odors. These odors will disappear over time.

OBSERVED PROBLEM	POSSIBLE CAUSE	REMEDY
Heater produces a clicking/ticking noise just after burner is lit or shut off	1. Metal expanding while heating or contracting while cooling	1. This is common with most heaters. If noise is excessive, contact qualified service person
Heater produces unwanted odors	1. Heater burning vapors from paint, hair spray, glues, cleaners, chemicals, new carpet, etc. (See <i>IMPORTANT</i> statement above) 2. Gas leak. See Warning statement at top of page	1. Open window and ventilate room. Stop using odor causing products while heater is running 2. Locate and correct all leaks (see <i>Checking Gas Connections</i> , page 12)
Heater shuts off in use (ODS operates)	1. Not enough fresh air is available 2. Low line pressure 3. ODS/pilot is partially clogged	1. Open window and/or door for ventilation 2. Contact local propane/LP gas company 3. Clean ODS/pilot (see <i>Cleaning and Maintenance</i> , page 18)
Gas odor even when control knob is in OFF position	1. Gas leak. See Warning statement at top of page 2. Control valve defective	1. Locate and correct all leaks (see <i>Checking Gas Connections</i> , page 12) 2. Replace control valve
Gas odor during combustion	1. Foreign matter between control valve and burner 2. Gas leak. See Warning statement at top of page	1. Take apart gas tubing and remove foreign matter 2. Locate and correct all leaks (see <i>Checking Gas Connections</i> , page 12)

SUN VALLEY STOVE COMPANY

VENT-FREE PROPANE/LP GAS STOVE HEATER

SPECIFICATIONS

Btu (Variable)	16,000/30,000
Type Gas	Propane/LP Only
Ignition	Piezo
Pressure Manifold	8" W.C.
Inlet Gas Pressure (in. of water)	
Maximum	14"
Minimum*	11"
Shipping Weight	28 lbs.

* For input adjustment

TECHNICAL SERVICE

You may have further questions about installation, operation, or troubleshooting. If so, contact DESA International's Technical Service Department at 1-800-DESA LOG (1-800-337-2564).

You can also visit DESA International's technical service web site at www.desatech.com.

WIRING DIAGRAM

(MSVFBPR Series Remote-Ready Models Only)

Note: For proper operation of optional accessories, the wires from the switch to the control must be connected exactly as shown.

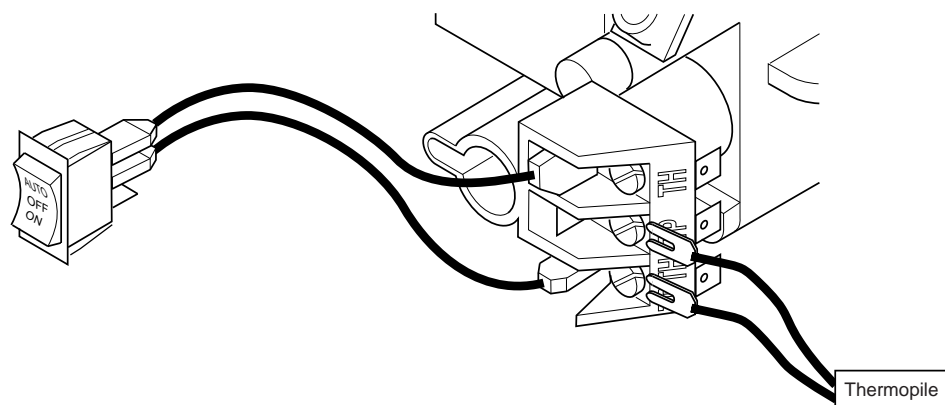

SERVICE HINTS

When Gas Pressure Is Too Low

- pilot will not stay lit
- burners will have delayed ignition
- heater will not produce specified heat

When Gas Quality Is Bad

- pilot will not stay lit
- burners will produce flames and soot
- heater will backfire when lit

You may feel your gas pressure is too low or gas quality is bad. If so, contact your local propane/LP gas supplier.

REPLACEMENT PARTS

Note: Use only original replacement parts. This will protect your warranty coverage for parts replaced under warranty.

PARTS UNDER WARRANTY

Contact authorized dealers of this product. If they can't supply original replacement part(s), call our Technical Service Department at 1-800-323-5190. When calling, have ready

- your name and address
- model and serial numbers of your heater
- how heater was malfunctioning
- type of gas used (propane/LP or natural gas)
- purchase date

Usually, we will ask you to return the defective part to the factory.

PARTS NOT UNDER WARRANTY

Contact authorized dealers of this product. If they can't supply original replacement part(s), call our Parts Department at 1-800-972-7879 for referral information. When calling, have ready

- model number of your heater
- the replacement part number

ACCESSORIES

Purchase these heater accessories from your local dealer. If they can not supply these accessories, call our Parts Department at 1-800-972-7879 for referral information. You can also write to the address listed on the back page of this manual.

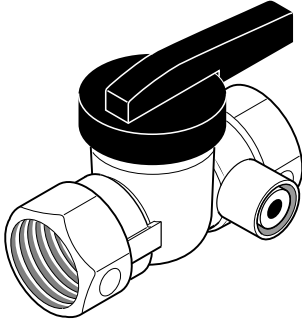

EQUIPMENT SHUTOFF VALVE - GA5010

For all models. Equipment shutoff valve with 1/8" NPT tap. Fits 1/2" NPT pipe.

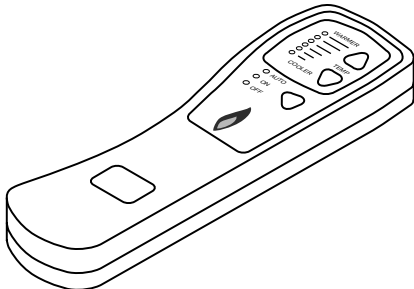

RECEIVER AND HAND-HELD THERMOSTAT REMOTE CONTROL KIT - GHRCT SERIES

For remote-ready models. Allows the gas log heater to be operated in a manually or thermostatically-controlled mode. You can turn the gas log heater on and off without ever leaving the comfort of your easy chair.

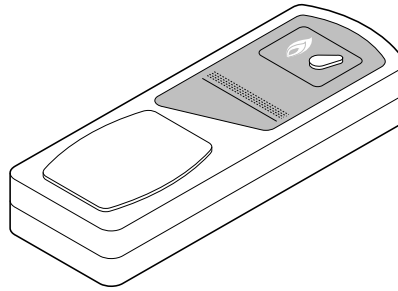

RECEIVER AND HAND-HELD REMOTE CONTROL KIT GHRC SERIES

For remote-ready models. Allows the gas log heater to be turned on and off by using a hand-held remote control.

WALL-MOUNT THERMOSTAT SWITCH GWMT1 (Not Shown)

For remote-ready models. The desired comfort setting can be selected on the wall thermostat and the log heater will automatically cycle from pilot to the heat setting selected.

WALL-MOUNT ON/OFF SWITCH - GWMS2 (Not Shown)

For remote-ready models. Allows the gas log heater to be turned on and off with a wall switch.

CLEANING KIT - GCK (Not Shown)

Your vent-free gas appliance requires regular cleaning and maintenance to prevent performance problems. This kit gives you the tools and instructions to make it easy to clean all critical areas of your appliance.

SUN VALLEY STOVE COMPANY VENT-FREE PROPANE/LP GAS STOVE HEATER

ILLUSTRATED
PARTS
BREAKDOWN

MSVFBPR

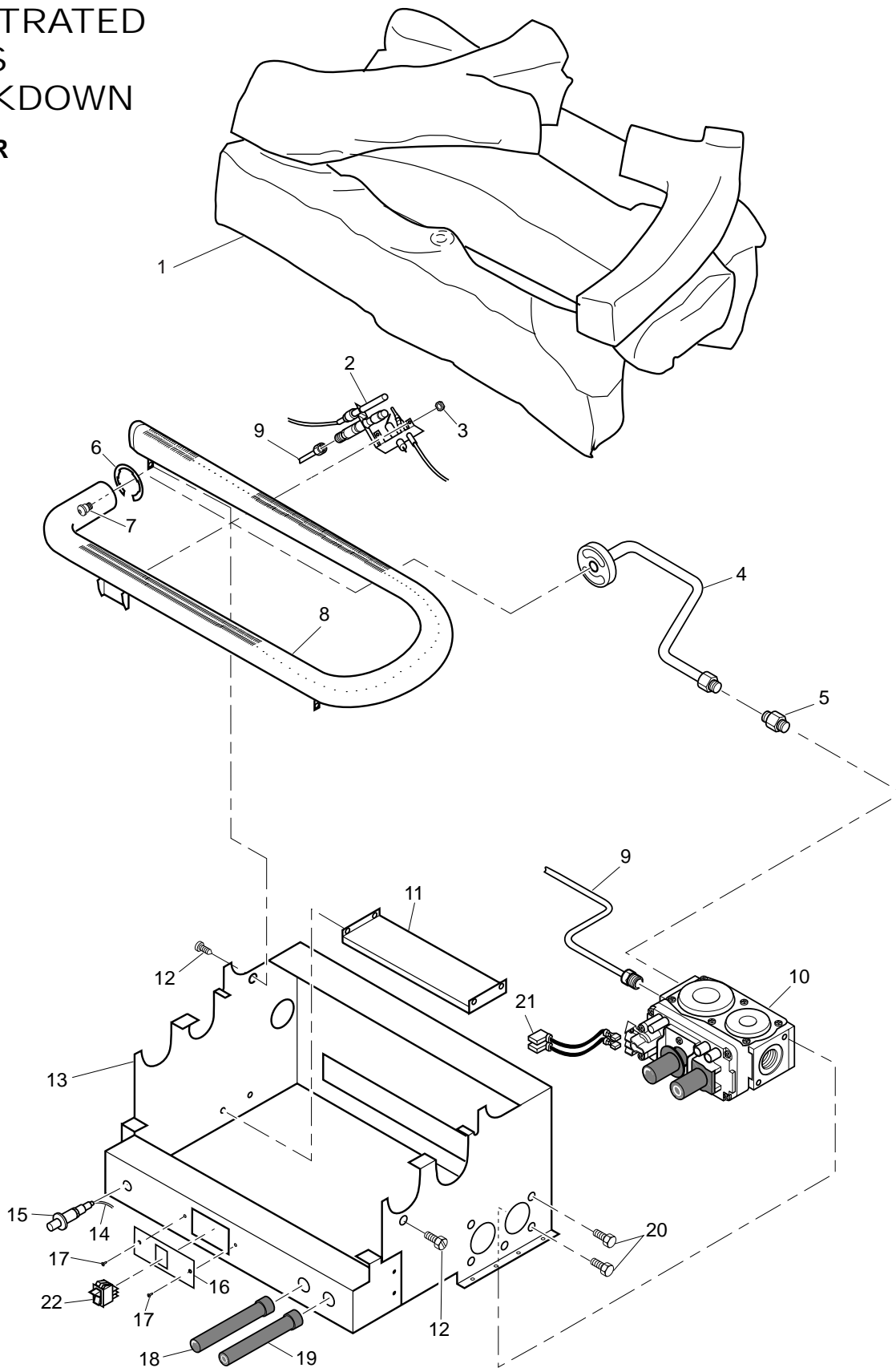

OWNER'S MANUAL

PARTS LIST

This list contains replaceable parts used in your heater. When ordering parts, follow the instructions listed under *Replacement Parts* on page 22 of this manual.

MSVFBPR

KEY NO.	PART NUMBER	DESCRIPTION	QTY.
1	104026-01	Stove Log	1
2	103778-01	ODS Pilot (LP)	1
3	098249-01	ODS Nut	2
4	104423-02	Burner Outlet Tube	1
5	098264-02	Male Connector	1
6	102843-01	Burner Clip	1
7	099056-19	Burner Orifice Injector	1
8	102980-01	Burner	1
9	099387-13	Pilot Tube	1
10	103781-02	Gas Control Valve	1
11	103345-02	Lower Bracket	1
12	M11084-38	Screw, #8 x .38	7
13	104383-02CK	Painted Base Assy	1
14	098271-07	Ignitor Cable	1
15	102445-01	Piezo Ignitor	1
16	103587-02CK	Plate, Switch	1
17	098304-01	Screw	2
18	103784-04	Flame Adjustment Knob	1
19	103784-03	Off-Pilot-On Knob	1
20	M12461-26	Screw, Hex Slit Wsr 10-32 x .38	4
21	103284-02	Wiring Harness	1
22	099998-01	Switch	1
PARTS AVAILABLE — NOT SHOWN			
	100563-01	Warning Plate	1
	103877-01	Lighting Instructions Plate	1
	100565-01	Warning Plate Fastener	1
	101137-04	Hardware Kit	1

SUN VALLEY STOVE COMPANY VENT-FREE PROPANE/LP GAS STOVE HEATER

ILLUSTRATED
PARTS
BREAKDOWN

MSVFBP

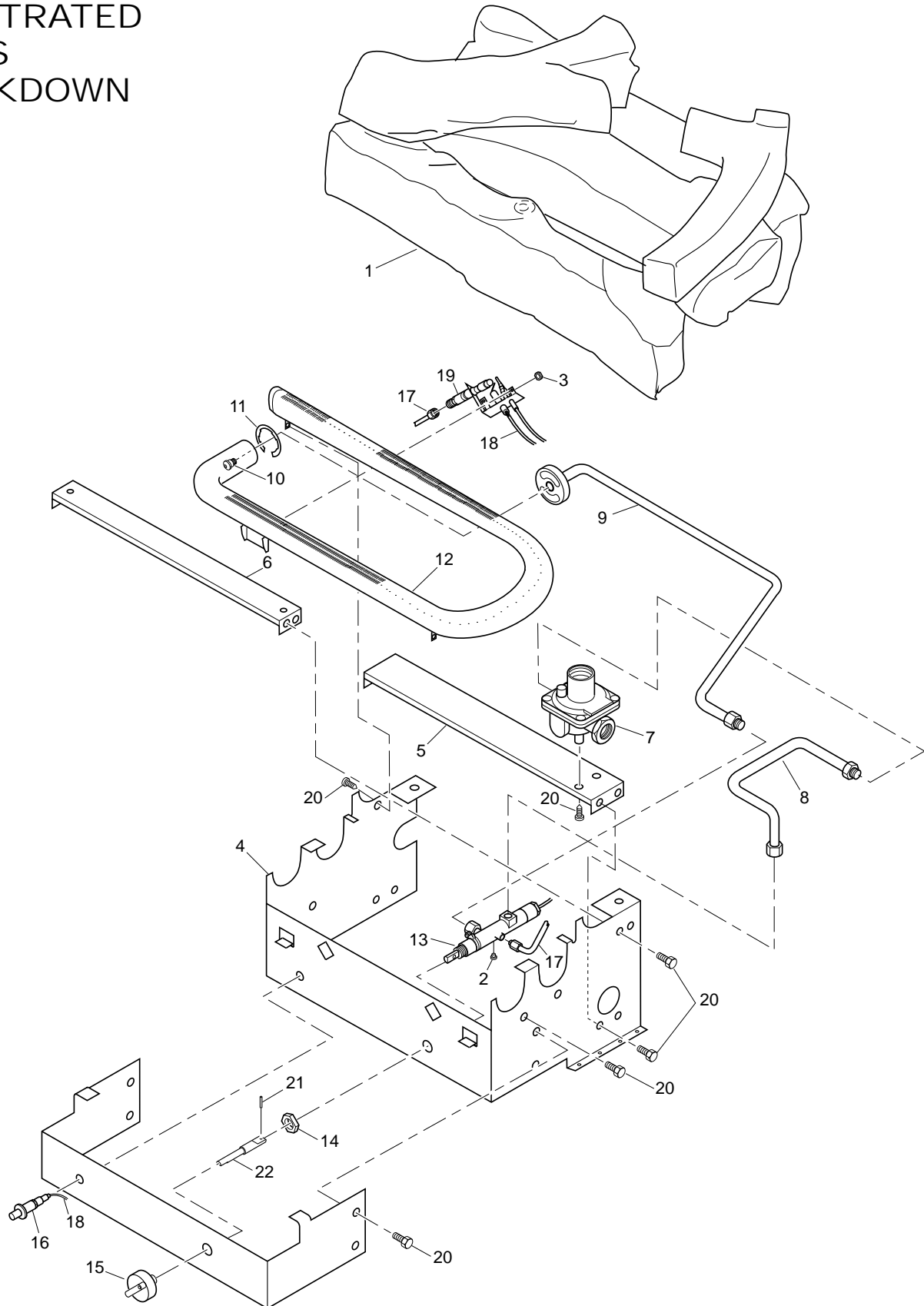

OWNER'S MANUAL

PARTS LIST

This list contains replaceable parts used in your heater. When ordering parts, follow the instructions listed under *Replacement Parts* on page 22 of this manual.

MSVFBP

KEY NO.	PART NO.	DESCRIPTION	QTY.
1	104026-01	Stove Log	1
2	098276-01	Hex Head Plug, 1/8" NPT	1
3	098249-01	Nut, M5	2
4	102776-05CK	Painted Base Assembly	1
5	102844-02	Lower Bracket	1
6	102966-02	Upper Bracket	1
7	098867-10	Gas Regulator	1
8	102798-01	Inlet Tube	1
9	102779-04	Outlet Burner Tube	1
10	099056-19	Burner Orifice Injector	1
11	102843-01	Burner Clip	1
12	102980-01	Burner	1
13	102568-08	Control Valve	1
14	098508-01	Valve Retainer Nut	1
15	099393-03	Control Knob	1
16	102445-01	Piezo Ignitor	1
17	099387-08	Pilot Tube	1
18	098271-07	Ignitor Cable	1
19	104286-01	ODS Pilot (LP)	1
20	M11084-38	Screw, Hex Head (#8-18 x .38)	15
21	098325-01	Roll Pin	1
22	098462-04	Control Rod Assembly	1
23	104055-01CK	Extension Base	1
PARTS AVAILABLE — NOT SHOWN			
	100563-01	Warning Plate	1
	101055-02	Lighting Instructions Plate	1
	100565-01	Warning Plate Fastener	1
	101449-06	Control Position Decal	1
	101137-04	Hardware Kit	1

SUN VALLEY STOVE COMPANY

VENT-FREE PROPANE/LP GAS STOVE HEATER

ILLUSTRATED PARTS BREAKDOWN

**SUN VALLEY STOVE
MC(*) SERIES
(*Indicates Color Suffix
Designation)**

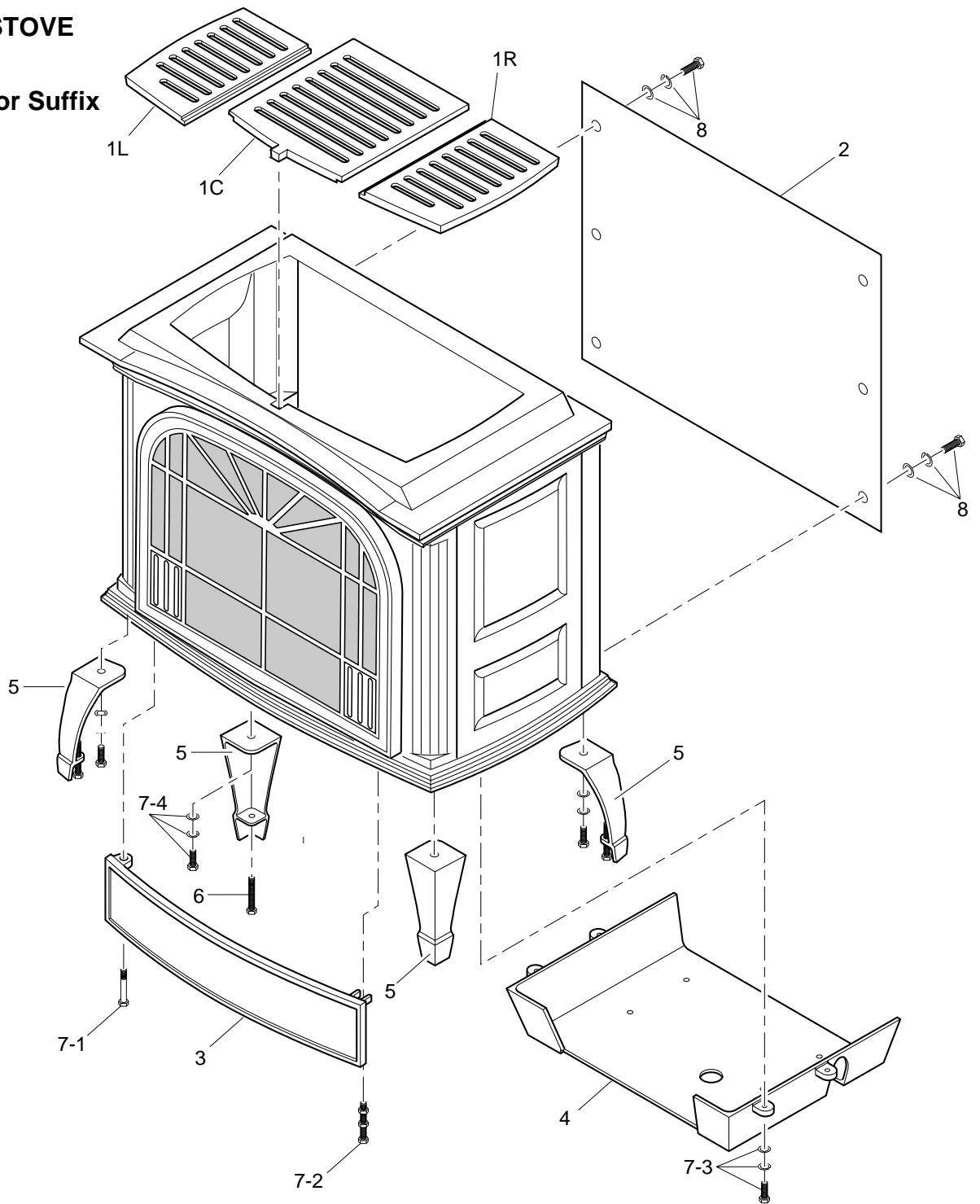

OWNER'S MANUAL

PARTS LIST SUN VALLEY STOVE MC(*) SERIES

(* Indicates Color Suffix Designation)

This list contains replaceable parts used in your stove. When ordering parts, follow the instructions listed under *Replacement Parts* on page 22 of this manual.

KEY NO.	PART NO.	DESCRIPTION	QTY.
1C	104171-02	Top Grate with Screen (Center) (Black Only)	1
1L	104171-03	Top Grate with Screen (Left) (Black Only)	1
1R	104171-04	Top Grate with Screen (Right) (Black Only)	1
2	104172-02	Stove Back Panel (Black Only)	1
3	104173-10	Bottom Door (Metalic Black)	1
	104173-11	Bottom Door (Porcelain Enamel Black)	1
	104173-12	Bottom Door (Porcelain Enamel Navy)	1
	104173-13	Bottom Door (Porcelain Enamel Almond)	1
	104173-14	Bottom Door (Porcelain Enamel Green)	1
	104173-15	Bottom Door (Porcelain Enamel Red)	1
4	104174-04	Stove Dropped Bottom	1
5	104175-10	One Leg (Metalic Black) (4 Total Per Stove)	1
	104175-11	One Leg (Porcelain Enamel Black) (4 Total Per Stove)	1
	104175-12	One Leg (Porcelain Enamel Navy) (4 Total Per Stove)	1
	104175-13	One Leg (Porcelain Enamel Almond) (4 Total Per Stove)	1
	104175-14	One Leg (Porcelain Enamel Green) (4 Total Per Stove)	1
	104175-15	One Leg (Porcelain Enamel Red) (4 Total Per Stove)	1
6	104176-01	Leg Leveler bolt M8 x 1.25 - 55mm Long (4 Total Per Stove)	1
7	104177-02	Hardware Kit	1
7-1	*	Door Hinge Step Bolt With Shoulder (1 Per Unit)	1
7-2	*	Door Catch Bolt M8 x 1.25 - 55mm Long With Two M8 Hex Nuts (1 Per Unit)	1
7-3	*	Bottom Floor Bolts M6 x 1 - 25mm Long With Flat Washer And Lock Washer (4 Per Unit)	1
7-4	*	Leg Bolts M6 x 1.25 - 20mm Long With Flat Washer And Lock Washer (4 Per Unit)	1
8	104178-01	Back Panel Bolts M6 x 1 - 20mm Long With Flat Washer And Lock Washer (6 Installed Per Unit)	1
PARTS AVAILABLE — NOT SHOWN			
	104108-06	Touch-up Spray Paint 12 oz Can (Metallic Black)	1
	104807-04	Touch-up Paint Bottle with Brush (Porcelain Enamel Black)	1
	104807-05	Touch-up Paint Bottle with Brush (Porcelain Enamel Navy)	1
	104807-06	Touch-up Paint Bottle with Brush (Porcelain Enamel Almond)	1
	104807-07	Touch-up Paint Bottle with Brush (Porcelain Enamel Green)	1
	104807-08	Touch-up Paint Bottle with Brush (Porcelain Enamel Red)	1
	106057-01	Back Panel Extension, Left (Included)	1
	106057-02	Back Panel Extension, Right (Included)	1
	104178-01	Back Panel Bolts M6 x 1 - 20mm Long With Flat Washer And Lock Washer (6 Installed Per Unit)	1

* Included In Hardware Kit

SUN VALLEY STOVE COMPANY

VENT-FREE PROPANE/LP GAS STOVE HEATER

ILLUSTRATED
PARTS
BREAKDOWN
SUN VALLEY STOVE
MCH(P) SERIES
HEPPLEWHITE STOVE
DESIGN

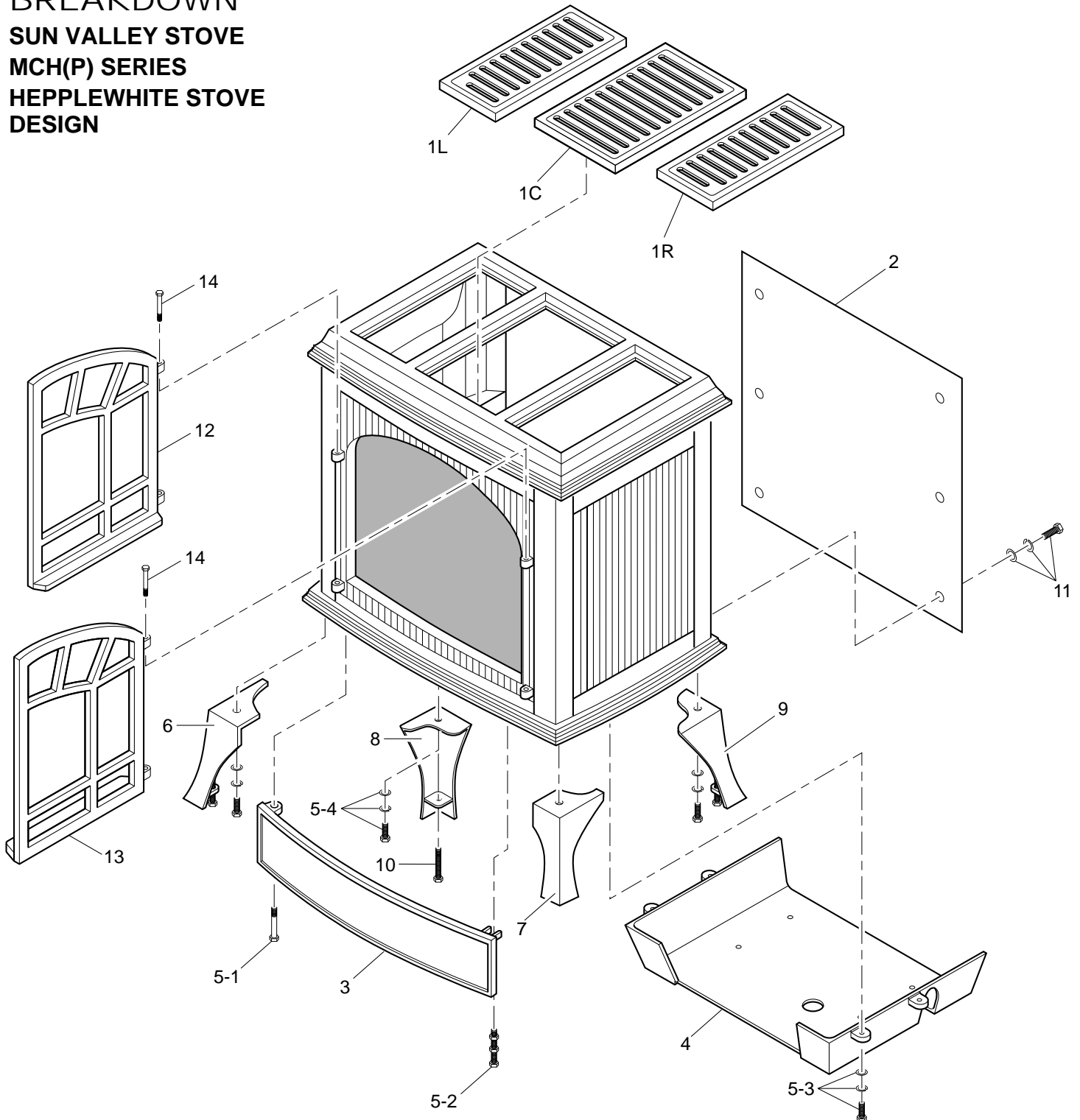

OWNER'S MANUAL

PARTS LIST SUN VALLEY STOVE MCH(P) SERIES HEPPLEWHITE STOVE DESIGN

This list contains replaceable parts used in your stove. When ordering parts, follow the instructions listed under *Replacement Parts* on page 22 of this manual.

KEY NO.	PART NO.	DESCRIPTION	QTY.	KEY NO.	PART NO.	DESCRIPTION	QTY.
1C	104171-13	Top Grate with Screen (Center) (Black Only)	1	9	104175-37	Right Rear Leg (Metallic Black)	1
1L	104171-14	Top Grate with Screen (Left) (Black Only)	1		104175-38	Right Rear Leg (Porcelain Enamel Black)	1
1R	104171-15	Top Grate with Screen (Right) (Black Only)	1		104175-39	Right Rear Leg (Porcelain Enamel Navy)	1
2	104172-03	Stove Back Panel (Black Only)	1		104175-40	Right Rear Leg (Porcelain Enamel Almond)	1
3	104173-16	Bottom Door (Metallic Black)	1		104175-41	Right Rear Leg (Porcelain Enamel Green)	1
	104173-17	Bottom Door (Porcelain Enamel Black)	1	10	104175-42	Right Rear Leg (Porcelain Enamel Red)	1
	104173-18	Bottom Door (Porcelain Enamel Navy)	1		104175-43	Right Rear Leg (Porcelain Enamel Metallic Green)	1
	104173-19	Bottom Door (Porcelain Enamel Almond)	1	11	104176-01	Leg Leveler bolt M8 x 1.25 - 55mm Long (4 Total Per Stove)	1
	104173-20	Bottom Door (Porcelain Enamel Green)	1	12	104178-01	Back Panel Bolts M6 x 1 - 20mm Long With Flat Washer And Lock Washer (6 Installed Per Unit)	1
	104173-21	Bottom Door (Porcelain Enamel Red)	1		107528-01	Left Door (Metallic Black)	1
	104173-22	Bottom Door (Porcelain Enamel Metallic Green)	1		107528-03	Left Door (Porcelain Enamel Metallic Green)	1
4	104174-05	Stove Dropped Bottom	1		107528-05	Left Door (Porcelain Enamel Almond)	1
5	104177-02	Hardware Kit	1		107528-07	Left Door (Porcelain Enamel Black)	1
5-1	*	Door Hinge Step Bolt With Shoulder (1 Per Unit)	1	13	107528-09	Left Door (Porcelain Enamel Green)	1
5-2	*	Door Catch Bolt M8 x 1.25 - 55mm Long With Two M8 Hex Nuts (1 Per Unit)	1		107528-11	Left Door (Porcelain Enamel Navy)	1
5-3	*	Bottom Floor Bolts M6 x 1 - 25mm Long With Flat Washer And Lock Washer (4 Per Unit)	1		107528-13	Left Door (Porcelain Enamel Red)	1
5-4	*	Leg Bolts M6 x 1.25 - 20mm Long With Flat Washer And Lock Washer (4 Per Unit)	1		107528-02	Right Door (Metallic Black)	1
6	104175-16	Left Front Leg (Metallic Black)	1	14	107528-04	Right Door (Porcelain Enamel Metallic Green)	1
	104175-17	Left Front Leg (Porcelain Enamel Black)	1		107528-06	Right Door (Porcelain Enamel Almond)	1
	104175-18	Left Front Leg (Porcelain Enamel Navy)	1		107528-08	Right Door (Porcelain Enamel Black)	1
	104175-19	Left Front Leg (Porcelain Enamel Almond)	1		107528-10	Right Door (Porcelain Enamel Green)	1
	104175-20	Left Front Leg (Porcelain Enamel Green)	1		107528-12	Right Door (Porcelain Enamel Navy)	1
	104175-21	Left Front Leg (Porcelain Enamel Red)	1		107528-14	Right Door (Porcelain Enamel Red)	1
	104175-22	Left Front Leg (Porcelain Enamel Metallic Green)	1		107527-01	Stainless Upper Door Hinge Bolt with Shoulder (4 Total Per Stove)	1
7	104175-23	Right Front Leg (Metallic Black)	1	PARTS AVAILABLE — NOT SHOWN			
	104175-24	Right Front Leg (Porcelain Enamel Black)	1		104108-06	Touch-up Spray Paint 12 oz. Can (Metallic Black)	1
	104175-25	Right Front Leg (Porcelain Enamel Navy)	1		104807-04	Touch-up Paint Bottle with Brush (Porcelain Enamel Black)	1
	104175-26	Right Front Leg (Porcelain Enamel Almond)	1		104807-05	Touch-up Paint Bottle with Brush (Porcelain Enamel Navy)	1
	104175-27	Right Front Leg (Porcelain Enamel Green)	1		104807-06	Touch-up Paint Bottle with Brush (Porcelain Enamel Almond)	1
	104175-28	Right Front Leg (Porcelain Enamel Red)	1		104807-07	Touch-up Paint Bottle with Brush (Porcelain Enamel Green)	1
	104175-29	Right Front Leg (Porcelain Enamel Metallic Green)	1		104807-08	Touch-up Paint Bottle with Brush (Porcelain Enamel Red)	1
8	104175-30	Left Rear Leg (Metallic Black)	1		106057-01	Back Panel Extension, Left (Included)	1
	104175-31	Left Rear Leg (Porcelain Enamel Black)	1		106057-02	Back Panel Extension, Right (Included)	1
	104175-32	Left Rear Leg (Porcelain Enamel Navy)	1		104178-01	Back Panel Bolts M6 x 1 - 20mm Long With Flat Washer And Lock Washer (6 Included Per Unit)	1
	104175-33	Left Rear Leg (Porcelain Enamel Almond)	1				
	104175-34	Left Rear Leg (Porcelain Enamel Green)	1				
	104175-35	Left Rear Leg (Porcelain Enamel Red)	1				
	104175-36	Left Rear Leg (Porcelain Enamel Metallic Green)	1				

* Included In Hardware Kit

WARRANTY INFORMATION

KEEP THIS WARRANTY

Model _____
Serial No. _____
Date Purchased _____

Always specify model and serial numbers when communicating with the factory.

We reserve the right to amend these specifications at any time without notice. The only warranty applicable is our standard written warranty. We make no other warranty, expressed or implied.

LIMITED WARRANTY VENT-FREE PROPANE/LP GAS LOG HEATERS AND STOVE CHASSIS

DESA International warrants this product to be free from defects in materials and components for four (4) years from the date of first purchase, provided that the product has been properly installed, operated and maintained in accordance with all applicable instructions. To make a claim under this warranty the Bill of Sale or cancelled check must be presented.

This warranty is extended only to the original retail purchaser. This warranty covers the cost of part(s) required to restore this heater to proper operating condition and an allowance for labor when provided by a DESA Authorized Service Center. Warranty part(s) MUST be obtained through authorized dealers of this product and/or DESA International who will provide original factory replacement parts. Failure to use original factory replacement parts voids this warranty. The heater MUST be installed by a qualified installer in accordance with all local codes and instructions furnished with the unit.

This warranty does not apply to parts that are not in original condition because of normal wear and tear, or parts that fail or become damaged as a result of misuse, accidents, lack of proper maintenance or defects caused by improper installation. Travel, diagnostic cost, labor, transportation and any and all such other costs related to repairing a defective heater will be the responsibility of the owner.

TO THE FULL EXTENT ALLOWED BY THE LAW OF THE JURISDICTION THAT GOVERNS THE SALE OF THE PRODUCT; THIS EXPRESS WARRANTY EXCLUDES ANY AND ALL OTHER EXPRESSED WARRANTIES AND LIMITS THE DURATION OF ANY AND ALL IMPLIED WARRANTIES, INCLUDING WARRANTIES OF MERCHANTABILITY AND FITNESS FOR A PARTICULAR PURPOSE TO FOUR (4) YEARS ON ALL COMPONENTS FROM THE DATE OF FIRST PURCHASE; AND DESA INTERNATIONAL'S LIABILITY IS HEREBY LIMITED TO THE PURCHASE PRICE OF THE PRODUCT AND DESA INTERNATIONAL SHALL NOT BE LIABLE FOR ANY OTHER DAMAGES WHATSOEVER INCLUDING INDIRECT, INCIDENTAL OR CONSEQUENTIAL DAMAGES.

Some states do not allow a limitation on how long an implied warranty lasts or an exclusion or limitation of incidental or consequential damages, so the above limitation on implied warranties, or exclusion or limitation on damages may not apply to you.

This warranty gives you specific legal rights, and you may also have other rights that vary from state to state.

For information about this warranty write:

DESA
INTERNATIONAL
2701 Industrial Drive
P.O. Box 90004
Bowling Green, KY 42102-9004
www.desatech.com

or

Sun Valley
Stove Company
Div. MASDA Corporation
Box D
Whippany, NJ 07981
www.sunvalleystove.com



105986 01

NOT A UPC

105986-01
Rev. C
06/00